

SURVEYING INSTRUMENTS

SOKKIA

SET4B

Electronic Total Station



OPERATOR'S MANUAL

1. PRECAUTIONS

- 1) When the SET4B is not used for a long time, check it at least once every three months.
- 2) Handle the SET4B with care. Avoid heavy shocks or vibration.
- 3) If any trouble is found on the rotatable portion, screws or optical parts (e.g. lens), contact our agent.
- 4) When removing the SET4B from the carrying case, never pull it out by force. The empty carrying case should then be closed to exclude dust.
- 5) Never place the SET4B directly on the ground.
- 6) Never carry the SET4B on the tripod to another site.
- 7) Protect the SET4B with an umbrella against direct sunlight, rain and humidity.
- 8) When the operator leaves the SET4B, the vinyl cover should be placed on the instrument.
- 9) Do not aim the telescope at the sun.
- 10) Always switch the power off before removing the internal battery.
- 11) Always remove the battery from the SET4B when returning it to the case.
- 12) Do not wipe the display **5**, keyboard **16** or the carrying case with an organic solvent.
- 13) When the SET4B is placed in the carrying case, follow the layout plan.
- 14) Make sure that the SET4B and the protective lining of the carrying case are dry before closing the case. The case is hermetically sealed and if moisture is trapped inside, damage to the instrument could occur.

2. PARTS OF THE INSTRUMENT

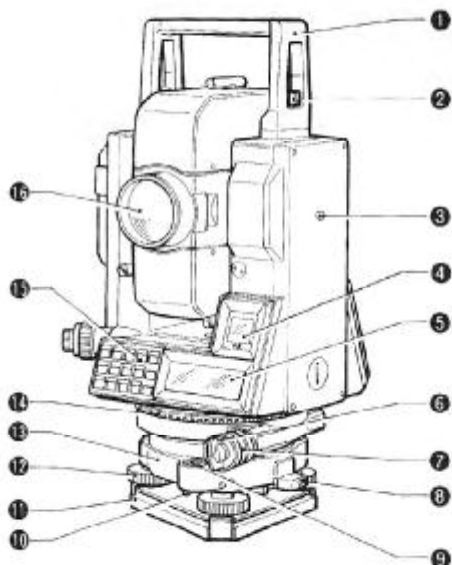

- | | |
|--------------------------|--------------------------------------|
| ① Handle | ⑩ Circular level adjusting screws |
| ② Handle securing screw | ⑪ Base plate |
| ③ Instrument height mark | ⑫ Levelling foot screw |
| ④ Sub-display | ⑬ Tribrach |
| ⑤ Main display | ⑭ Horizontal circle positioning ring |
| ⑥ Lower clamp | ⑮ Keyboard |
| ⑦ Lower clamp cover | ⑯ Objective lens |
| ⑧ Tribrach clamp | |
| ⑨ Circular level | |

CONTENTS

1. PRECAUTIONS	1
2. PARTS OF THE INSTRUMENT	2
3. FEATURES	4
4. KEY FUNCTIONS	6
5. BATTERY BDC18: MOUNTING AND CHECK	9
6. SETTING UP THE INSTRUMENT	11
6.1 CENTRING THE SET4B BY ADJUSTING TRIPOD LEG LENGTH	11
6.2 FOCUSSING	11
7. INDEXING THE VERTICAL AND HORIZONTAL CIRCLES	12
8. ANGLE MEASUREMENT	14
8.1 SELECTION OF HORIZONTAL ANGLE DISPLAY	14
8.2 SETTING THE HORIZONTAL ANGLE TO ZERO	14
8.3 SET THE HORIZONTAL ANGLE TO A REQUIRED VALUE	14
8.4 TILT ANGLE DISPLAY AND TILT COMPENSATION OF MEASURED ANGLES	15
8.5 DISPLAY AND RETICLE ILLUMINATION	16
9. PREPARATION FOR DISTANCE MEASUREMENT	17
9.1 ENTRY OF PRISM CONSTANT VALUE	17
9.2 ATMOSPHERIC CORRECTION	18
9.3 SELECTION OF THE MEASUREMENT MODE ...	20
9.4 EARTH-CURVATURE AND REFRACTION CORRECTION	21
9.5 PRISM SIGHTING FOR ANGLE AND DISTANCE MEASUREMENT	22

10. DISTANCE MEASUREMENT	23
11. PREPARATION FOR COORDINATE MEASUREMENT	25
11.1 INPUT OF INSTRUMENT AND TARGET HEIGHTS	25
11.2 INPUT OF INSTRUMENT STATION COORDINATES	26
11.3 INPUT OF BACKSIGHT STATION COORDINATES	27
11.4 SETTING THE AZIMUTH ANGLE FROM THE INSTRUMENT AND BACKSIGHT STATION COORDINATES	28
12. COORDINATE MEASUREMENT	29
12.1 3-DIMENSIONAL COORDINATE MEASUREMENT	29
12.2 TRAVERSE-STYLE COORDINATE MEASUREMENT	30
13. REMOTE ELEVATION MEASUREMENT	32
14. MISSING LINE MEASUREMENT	34
15. SETTING OUT MEASUREMENT	36
15.1 HORIZONTAL ANGLE SETTING OUT MEASUREMENT	36
15.2 DISTANCE SETTING OUT MEASUREMENT	37
15.3 COORDINATES SETTING OUT MEASUREMENT	39
16. INSTRUMENT PARAMETER SETTINGS	42
16.1 ENTRY TO PARAMETER SETTING MODE	42
16.2 SUMMARY OF PARAMETER OPTIONS	43
16.3 CHANGING INSTRUMENT PARAMETER OPTIONS	45
17. DATA RECORDING ON AN EXTERNAL DEVICE ...	49

18. CHECKS AND ADJUSTMENTS	56
18.1 ANGLE MEASURING FUNCTION	56
18.1.1 Plate level	56
18.1.2 Circular level	58
18.1.3 Reticle adjustments	58
18.1.4 Coincidence of the distance measuring axis with the reticle	62
18.1.5 Optical plummet	63
18.2 DISTANCE MEASURING FUNCTION	64
18.2.1 Check flow chart	64
18.2.2 Additive distance constant	66
19. MANUALLY INDEXING VERTICAL CIRCLE BY FACE LEFT, FACE RIGHT READINGS	68
20. FOR DISTANCE MEASUREMENT OF THE HIGHEST ACCURACY	70
20.1 ACCURACY OF MEASUREMENT OF ATMOSPHERIC CONDITIONS	70
20.2 TO OBTAIN THE ATMOSPHERIC PRESSURE ...	70
21. POWER SUPPLIES	72
22. REFLECTING PRISMS AND ACCESSORIES	74
23. STANDARD EQUIPMENT	76
24. OPTIONAL ACCESSORIES	77
24.1 INTERFACE CABLES DOC1, DOC25/DOC26/DOC27	77
24.2 ELECTRONIC FIELD BOOK SDR SERIES	77
24.3 DIAGONAL EYEPIECE DE18	78
24.4 SOLAR FILTER OF1/OF1A	78
25. SPECIFICATIONS	79
26. MAINTENANCE	82

G111 - Sokkia

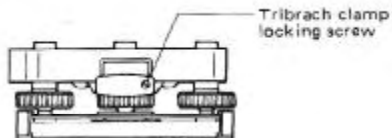

IMPORTANT

When the new SET4B is shipped, the tribrach clamp is fixed with a screw. Loosen it and leave it loose.

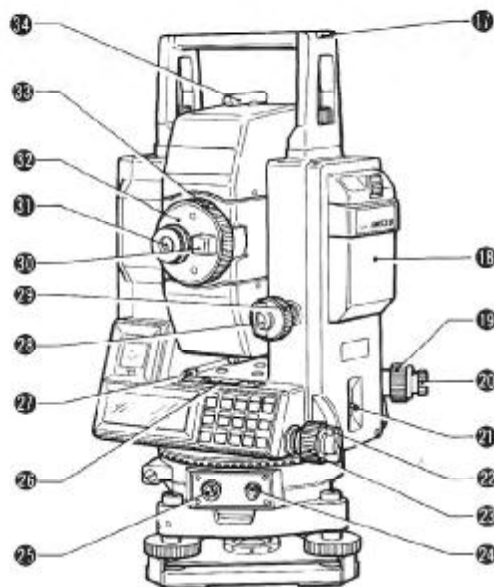

- | | |
|------------------------------------|---------------------------------------|
| 17 Tubular compass slot | 21 Plate level |
| 18 Battery BDC18 | 22 Plate level adjusting screw |
| 19 Optical plummet focussing ring | 23 Vertical clamp |
| 20 Optical plummet eyepiece | 24 Vertical fine motion screw |
| 21 Power switch | 25 Telescope transitting knob |
| 22 Horizontal clamp | 26 Telescope eyepiece |
| 23 Horizontal fine motion screw | 27 Telescope reticle adjustment cover |
| 24 Data output connector | 28 Telescope focussing ring |
| 25 External power source connector | 29 Peep sight |

3. FEATURES

- Distance and angle measurements are electronically measured and displayed on a main display located on both faces of the instrument. These 3-line, 48-character alphanumeric dot-matrix displays can simultaneously show measured or stored angle and distance data or N- and E-coordinates and height, or display prompts and messages. The 3-line, 12-character sub-display on each face of the instrument shows the atmospheric correction, prism constant value and instrument mode.
- Advanced software functions include the calculation of 3-dimensional coordinates, automatic calculation and setting of the azimuth angle from input coordinates, traverse-style measurement, and setting out from input coordinates, in addition to the standard functions of remote elevation measurement, missing line measurement and setting out by distance and angle. The distance measurement can be set to single or repeat readings with a choice of fine, coarse or tracking-type measurement modes. The instrument parameter settings are stored in an internal memory which can be changed by key operation, and remain stored in the memory even after power off. The atmospheric correction ppm values are calculated by the instrument after input of the temperature and pressure values. A micro-computer constantly checks the instrument operation; if an error is detected, an error message or code is displayed.
- Both the horizontal and vertical circles are provided with 0 index points. The horizontal index can be set to any direction and the value is stored in the short-term memory so that even after power is switched off (i.e. battery change), the previous index position can be recovered when the instrument is switched on and the circle is indexed again (in auto indexing mode).

- The tilt angles of the vertical axis are measured by an internal 2-axis tilt sensor. These tilt angles can be displayed for use in accurately levelling the instrument, and can also be used to automatically compensate the vertical and horizontal angles.
- The SET4B RS-232C-compatible data output connector allows 2-way communication and output of data for recording with an external device.

4. KEY FUNCTIONS

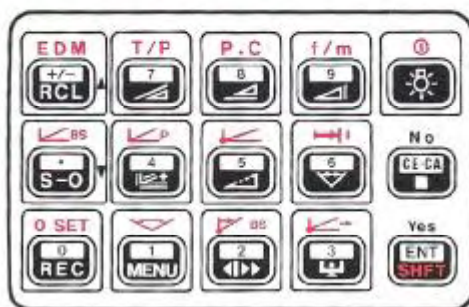

- 
 - Select the distance measuring mode ( + )
 - Change the sign of the data input value
 - Recall data from the memory
 - Move to previous option ()
- 
 - Enter the Atmospheric correction (Temperature/Pressure values ( + )
 - Enter "7"
 - Measure slope distance
- 
 - Enter the prism constant value ( + )
 - Enter "8"
 - Measure horizontal distance
- 
 - Change meters ↔ feet for 5 seconds ( + )
 - Enter "9"
 - Measure height difference
- 
 - EDM power ON/OFF for locating prism ( + )
 - Display and reticle illumination ON
- 
 - Enter Backsight station coordinates ( + )
 - Enter "." (Decimal point)
 - Setting out measurement (+ mode key)
 - Move to next option ()

- 
 - Enter coordinates of point to be set out ( + )
 - Enter "4"
 - Measure 3-dimensional coordinates
- 
 - Enter Instrument station coordinates ( + )
 - Enter "5"
 - Measure remote elevation
- 
 - Enter distance setting out data ( + )
 - Enter "6"
 - Missing line measurement
- 
 - Clear entered data
 - Stop measurement and transfer to basic mode
 - Exit from mode
 - Enter "No"
- 
 - Set the horizontal angle to zero/in Missing line measurement, change the starting ( + ) point
 - Enter "0"
 - Output data to an external device
- 
 - Set horizontal circle to a required value ( + )
 - Enter "1"
 - Transfer to menu mode
- 
 - Set azimuth angle from Instrument and Backsight station coordinates ( + )
 - Enter "2"
 - Select horizontal angle right, left or repetition
- 
 - Set Instrument station coordinates and azimuth angle using data from previous station ( + )
 - Enter "3"
 - Transfer to theodolite mode
 - Display tilt angle (When instrument is in Theodolite mode and the "Tilt correction" parameter is ON)
- 
 - Enter data into memory
 - Select/release SHIFT mode (Upper key functions)
 - Enter "Yes"

MODE DIAGRAM

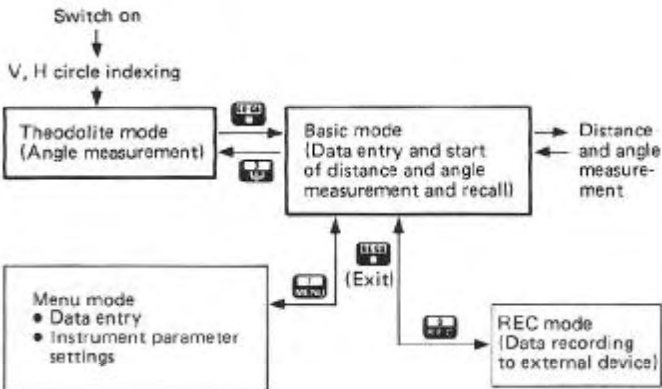

DISPLAY SYMBOLS

Upper Display:

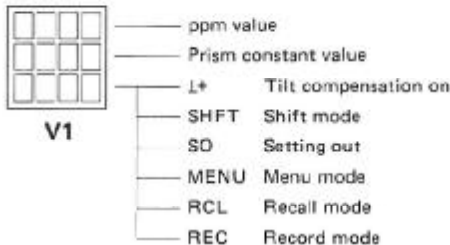

The main lower display shows program prompts, stored, entered and measured data, and error messages.

5. BATTERY BDC18: MOUNTING AND CHECK



Self check ok

Battery level 3

ppm
p.c
↑

V1

ZA 0 SET
HAR 0 SET

- 1) Ensure that the SET4B power switch **(1)** is off.
- 2) Mount the BDC18 battery in the SET4B. Hold the left standard and push the battery until a click is heard. Confirm that the battery is securely mounted.
- 3) Level the SET4B instrument.
- 4) Instrument and battery check:
Switch the SET4B power switch **(2)** on.

♪ The audio tone sounds and the instrument performs self-diagnostic checks. "Self check ok" is displayed for two seconds when the instrument has successfully completed the checks.

The remaining battery power is then displayed for two or three seconds in the format "Battery level X" where X represents the battery level as follows:

Code	0 less than 1 hr	[Angle-only measurement at 25°C]
	1 less than 1.5 hrs	
	2 less than 5 hrs	
	3 less than 9 hrs	

♪ The display of "ZA/HAR 0 SET" indicates that the instrument is ready for vertical and horizontal circle indexing. If "HAR 0°00'00" " or "ZA Face 1" is displayed, the Horizontal/Vertical indexing is set to "Manual". See "Instrument parameter settings" on page 42.

Battery is low

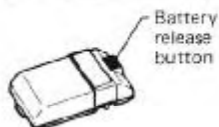

If "Battery is low" is displayed, the BDC18 battery should be recharged or replaced by a charged battery.

To remove the battery, ensure that the SET4B power switch is off, then push down the battery release button.

Memory error

A display of "Memory error" after more than 1 week of power off means that previously-entered data such as station and backsight coordinates, instrument and target heights and setting out information has been cleared from the short term memory.



V1

- When the 1+ symbol is shown on the small display, the vertical and horizontal angles are automatically compensated for small tilt errors using the 2-axis tilt sensor. The tilt sensor has a range of $\pm 3'$.

Out of range

If "Out of range" is displayed, the SET4B tilt sensor is indicating that the instrument is off-level. The instrument should be re-levelled using the plate level bubble.

Instrument parameters: See page 42—.

The "Tilt correction (Dual axis)" parameter can be used to switch on (Yes) and off (No) the automatic angle compensation.

For example, the compensation should be switched off if the displayed values are unsteady due to vibration or strong wind.

6. SETTING UP THE INSTRUMENT

6.1 CENTRING THE SET4B BY ADJUSTING TRIPOD LEG LENGTH

- 1) Make sure that:
 - a. The tripod head is approximately level.
 - b. The tripod shoes are firmly fixed in the ground.
- 2) Set the SET4B on the tripod head. Tighten the centring screw.
- 3) Focus on the surveying point:
 - a. Turn the optical plummet eyepiece ⑩ to focus on the reticle.
 - b. Turn the optical plummet focussing ring ⑪ to focus on the surveying point.
- 4) Turn the levelling foot screws ⑫ to centre the surveying point in the reticle.
- 5) Observe the off-centre direction of the bubble in the circular level ⑨. Shorten the leg nearest that direction, or extend the leg farthest from that direction.
Generally, two legs must be adjusted to centre the bubble.
- 6) When centring of the circular level is completed, turn the levelling screws to centre the plate level ⑬ bubble.
- 7) Look through the optical plummet again. If the surveying point is off-centre, loosen the centring screw to centre the surveying point on the reticle. Tighten the centring screw.
- 8) Repeat 6), 7) if the plate level bubble is off-centre.

6.2 FOCUSING

- 1) Looking through the telescope, turn the eyepiece fully clockwise, then anticlockwise until just before the reticle image becomes blurred. In this way, frequent refocussing can be dispensed with, since your eye is focussed at infinity.
- 2) Loosen the vertical ⑲ and horizontal clamp ⑳.
Bring the target into the field of view with the peep sight ㉑.
Tighten both clamps.
- 3) Turn the focussing ring ㉒ and focus on the target.
Sight the target centre using the vertical ⑲ and horizontal fine motion screws ㉓. Focus on the target until there is no parallax between the target and the reticle.

Parallax:

Relative displacement of target image in respect to the reticle when observer's head is moved slightly before the eyepiece.

If sighting is carried out before parallax is eliminated, this will introduce errors in reading and will impair your observations.

7. INDEXING THE VERTICAL AND HORIZONTAL CIRCLES

Switch the SET4B on, and ensure that the display shows the "ZA/HAR 0 SET" prompt.

(If H and/or V circle Indexing parameters are "Manual", this procedure is different.)

ZA	0	SET
HAR	0	SET

---- Waiting for vertical circle indexing

---- Waiting for horizontal circle indexing



1) Vertical circle indexing:

Loosen the vertical clamp  and transit the telescope completely. (Indexing occurs when the objective lens crosses the horizontal plane in face left.)

ZA	81°38'45"	
HAR	0	SET

♪ The audio tone sounds and the vertical angle (ZA) is displayed.



ZA	81°38'45"
HAR	314°50'35"

- 2) Horizontal circle indexing:
Loosen the horizontal clamp  and rotate the upper part of the instrument through 360°.

♪ The audio tone sounds and the horizontal angle right (HAR) is displayed.

Measurement can now take place

The instrument is now in Theodolite (Angle measurement) mode.

Note: Each time the instrument is switched on, the vertical and horizontal indices must be re-determined. However, note that if the instrument was only switched off for a short time (less than 1 week), the previous horizontal 0° position will be recovered when the horizontal circle is indexed again.

Instrument parameters: See page 42—.

The "V indexing" parameter can be used to change the vertical circle indexing method. Options are indexing by transiting the telescope as above or indexing by face left, face right sightings. See page 68.

The "H indexing" parameter can be used to change the horizontal circle indexing method. Options are indexing by rotating the upper part as above or indexing and zero setting at power on.

8. ANGLE MEASUREMENT

Go to distance measurement: 

Return to angle measurement: 

8.1 SELECTION OF HORIZONTAL ANGLE DISPLAY

The  key can be used to select the required horizontal angle display.

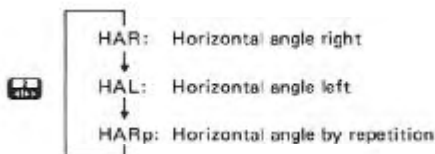

The options are:



8.2 SETTING THE HORIZONTAL ANGLE TO ZERO



 + 

ZA	81°38'45"
HAR	0°00'00"

Press  +  to set the horizontal angle value to zero.



This zero position is memorized for up to a week after power off.

8.3 SET THE HORIZONTAL ANGLE TO A REQUIRED VALUE

 + 

H angle
HAR

e.g. Set 90°30'20" to reference target R.

1) Press  + . The display prompts for the input of the horizontal angle value.

< Input value >



H angle
HAR 90.3020

2) Input the value as 90,3020 and press  to enter the value.

The display returns to the angle measurement display and the horizontal angle is set to 90°30'20".



ZA	81°38'45"
HAR	90°30'20"

- The input angle value should be between 0°00'00" and 359°59'55".
- To correct a mis-entered value, press  to clear the wrong value then input the correct value.
- To exit from the angle entry function, press  two times.

Instrument parameters: See page 42—.

The "Vertical angle display mode" parameter can be used to change the displayed vertical angle. Options are 0° at zenith, 0° horizontal on face left, and 0° horizontal $\pm 90^\circ$.

8.4 TILT ANGLE DISPLAY AND TILT COMPENSATION OF MEASURED ANGLES

The SET4B is provided with a 2-axis (X, Y) tilt sensor which is used to automatically correct the vertical and horizontal angles for errors due to the non-verticality of the vertical axis. The tilt angle X and Y values can be displayed.

Note that the "Tilt correction (Dual axis)" parameter must be set to ON (I+ symbol shown in small display) to obtain tilt-corrected angles and the tilt angle display. See page 42—.

ZA	81°38'45"
HAR	314°50'35"

- 1) In the angle measurement mode, press .



The X and Y tilt angles are displayed.



Tilt angle	
X	0°01'25"
Y	-0°00'45"

----- X: Tilt angle in sighting axis direction.

----- Y: Tilt angle in horizontal axis direction.

To exit from the tilt angle display, press  again to return to theodolite mode, or press  to go to Basic mode.

- The range of the tilt sensor is $\pm 3'$. If the tilt angle is greater than this, "Out of range" is displayed.

Notes for horizontal angle tilt compensation

- The formula used for calculation of the compensation value applied to the horizontal angle uses the tilt and vertical angles as shown below:

$$\text{Compensated horizontal angle} = \text{Measured horizontal angle} + \frac{\text{Tilt angle } Y}{\tan(\text{Vertical angle})}$$

Therefore, when the SET4B is not perfectly levelled, changing the vertical angle by rotating the telescope will cause the displayed (compensated) horizontal angle value to change. (The displayed horizontal angle value will not change during telescope rotation when the instrument is correctly levelled.)

- When the measured vertical angles are within $\pm 1^\circ$ of the zenith or nadir, tilt compensation is not applied to the horizontal angle. In this situation, the displayed horizontal angle value flashes to show that the tilt compensation is not being applied.

8.5 DISPLAY AND RETICLE ILLUMINATION

For work in low-light conditions, the  key can be used to switch on the display and reticle illumination.

Instrument parameters: See page 42–.

The “Reticle illumination” and “Backlight control” parameters can be used to change the illumination function. “Reticle illumination” has the option of bright or dim illumination, and “Backlight control” allows the user to select a 30-second automatic cut-off function or to switch on/off by pressing .

9. PREPARATION FOR DISTANCE MEASUREMENT

9.1 ENTRY OF PRISM CONSTANT VALUE

The prism constant value can be entered for correction of the measured distances.

The stored prism constant value is shown in the small upper display of the SET4B and is stored in the permanent memory.

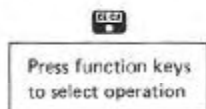

- 1) Press **F.F.** to enter the Basic mode from the Angle measurement mode.
"Press function keys . . ." is displayed.

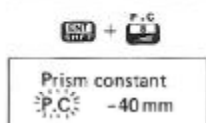

- 2) Press **ENT/SHIFT** + **P.C.** to enter the prism constant setting display.

---- The previous stored prism constant value is displayed.

- 3) To change the prism constant, input the required value (taking care with the sign) and press **ENT/SHIFT** to enter the value in the memory. The instrument returns to the "Press function keys . . ." display.

e.g. To input a prism constant correction value of -30 mm, enter:

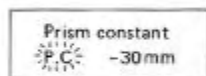

- The prism constant value can be input as a value from -99mm to +99mm in 1 mm steps.
- To correct a mis-entered value, press **F.F.** to clear the wrong value, then enter the correct value.
- To exit from the prism constant setting mode to the Basic mode, press **F.F.** two times.

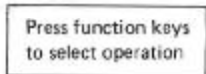
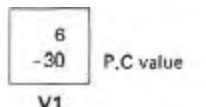

9.2 ATMOSPHERIC CORRECTION

In the SET4B it is possible either to set 0ppm, or to input the temperature and pressure from which the ppm correction will be automatically calculated and applied.

The stored ppm value is displayed on the small upper SET4B display and is stored in the temporary memory for about 1 week after power off.

Press function keys
to select operation



Select

1. Set 0 ppm
2. Set value

- 1) From the SET4B Basic mode ("Press function keys...") displayed, press + to enter the Atmospheric correction setting display.

- Atmospheric correction not applied (ppm value = 0),
- Enter temperature and pressure values for automatic ppm calculation and correction.



0 ppm

- 2) Either:
Press to set 0ppm (no atmospheric correction). The SET4B returns to the basic mode after setting 0ppm.



15 °C
P. 1013 mbar

< Input temp >

T. 15 °C
 1013 mbar

< Input press >

- 3) Or:
 - a) Press to input the temperature and pressure values. The display prompts for the input of the Temperature (T) value. Use the keyboard to input the value and press to enter it. The display prompts for the input of the Pressure (P).
 - b) Input the pressure value and press to enter it. The ppm value is calculated and displayed on the SET4B small upper display and this value is applied to all measured distance values. The instrument returns to the Basic mode.

6 ppm
-30 P.C

V1

Press function keys
to select operation

- The entered values should be between -30°C and +60°C (-22°F and 140°F) for temperature, and between 500mb and 1400mb (375mmHg and 1050 mmHg) for pressure.
- To correct a mis-entered value, press  to clear the wrong value then input the correct value. The ppm value is memorized for about a week after power off.
- When temperature is known in °C and pressure is in mb, the following formula is used:

$$\text{ppm} = 278.96 - \frac{0.2904 \times P \text{ (mb)}}{1 + 0.003661 \times T \text{ (°C)}}$$

Instrument parameters: See page 42—.

The "Temp & Press units" parameter can be used to change the units for temperature and pressure entry. Options are °C, °F, mb, mmHg, inchHg.

9.3 SELECTION OF THE MEASUREMENT MODE

The distance measurement mode can be set to fine or coarse, single or repeat measurements or tracking measurements using the

EDM **SHIFT** + **EDM** **RCL** keys.

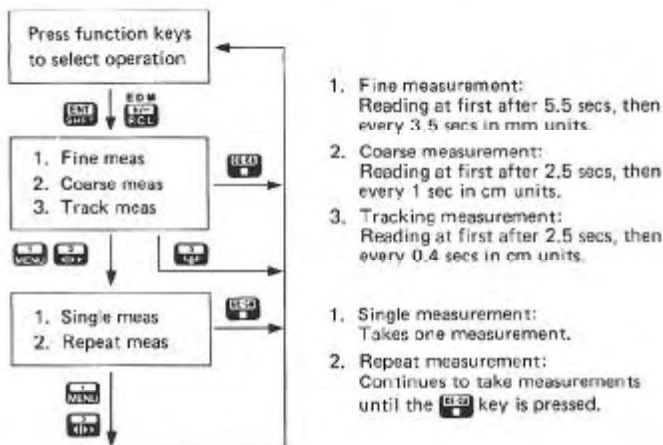

- 1) From Basic mode ("Press function keys . . ." displayed), press **EDM** **SHIFT** + **EDM** **RCL** to enter the measurement mode setting menu. The cursor flashes at the currently-selected option.
- 2) Press **EDM** **RCL**, **EDM** **SHIFT** or **EDM** **RCL** to select the Fine, Coarse or Tracking modes. If Tracking mode is selected, the mode is set and the instrument returns to the "Press function keys . . ." display.
- 3) For Fine or Coarse measurements, the display prompts for the selection of 1) Single or 2) Repeat measurements. Input **EDM** **RCL** or **EDM** **SHIFT**, then the instrument returns to the Basic mode.
 - To exit from the measurement mode setting displays, press **EDM** **RCL**. The previously-stored values are retained in the instrument memory.
 - When tilt compensation is not being applied, all the above measurement times are 0.2 sec less.

9.4 EARTH-CURVATURE AND REFRACTION CORRECTION

The earth-curvature and refraction correction can be selected using the "C + R correction" Internal parameter. This correction is applied in the measurement of horizontal distance and height difference and the Atmospheric refraction constant K can be chosen as either 0,142 or 0,20.

When the correction is applied, the following formulas are used:

- Horizontal distance after correction:

$$H' = S \times \sin Z - \frac{1 - \frac{K}{2}}{R} \times S^2 \times \sin Z \times \cos Z$$

- Height difference after correction:

$$V' = S \times \cos Z + \frac{1 - \frac{K}{2}}{2R} \times S^2 \times \sin^2 Z$$

When the correction is not applied, the following formulas are used:

- Horizontal distance: $H = S \times \sin Z$

- Height difference: $V = S \times \cos Z$

where:

S: Slope distance value (after atmospheric correction)

Z: Vertical angle (0° at zenith)

K: Atmospheric refraction constant (A value of 0,142 or 0,20 can be selected using the Internal parameters. See page 42—.)

R: Radius of the earth (6.372×10^6 m)

Instrument parameters: See page 42—.

The "C + R correction" parameter can be used to switch on and off the curvature and refraction correction and to select the refraction constant value. Options are: 1. Off, 2. On: K = 0.142, 3. On: K = 0.20.

9.5 PRISM SIGHTING FOR ANGLE AND DISTANCE MEASUREMENT

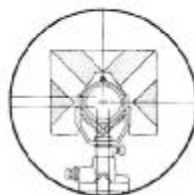

- 1) Sight the centre of the reflecting prism with the SET4B telescope,

Press function keys
to select operation

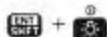

Signal

Signal *

- 2) To confirm the sighting, if required: From the Basic mode ("Press function keys . . ." displayed), press **FNC/SHFT** + **[Power]** to switch the EDM power on for about 2 minutes to allow prism sighting. "Signal" is displayed.

When the SET4B is correctly sighting the prism, and the returned beam strength is adequate for measurement, a "*" symbol appears on the display and an optional audio tone is output.



Press function keys
to select operation

- 3) Press **FNC/SHFT** + **[Power]** again to switch off the power to the EDM unit.

*Instrument parameters: See page 42—.

The "Return signal audio tone" parameter can be used to switch on and off the audio tone which is output when the EDM is correctly sighting the reflecting prism.

10. DISTANCE MEASUREMENT

Before distance measurement, ensure that:

- ① The SET4B is set up correctly over the surveying point.
- ② The remaining battery power is adequate.
- ③ The vertical and horizontal circles have been indexed.
- ④ The prism constant, curvature and refraction and atmospheric corrections have been correctly set. (See Section 9.)
- ⑤ The SET4B is correctly sighting the reflecting prism and the returned beam strength is adequate for measurement.

Press function keys
to select operation



S dist

S	234.567 m
ZA	81°12'35"
HAR	12°23'45"

- 1) From the Basic mode ("Press function keys..." displayed), press to measure the slope distance.

"S dist" is displayed while the SET4B measures the distance.

After 5.5 seconds (fine measurement mode), the slope distance value and the vertical and horizontal angles are displayed.

- 2) In the repeat and tracking measurement modes, press to stop the distance measurement. (In single measurement mode, this step is unnecessary.)

Horizontal distance and height difference:

To measure horizontal distance or height difference, follow the same procedure as described above, but in step 1), press for horizontal distance or press for height difference.



H dist

H	231.812 m
ZA	81°12'35"
HAR	12°23'45"

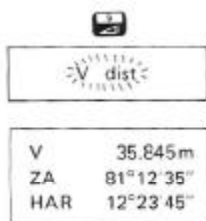

Note: A display of "Signal off" or "Timeout" means that the returned beam strength has decreased during measurement. Ensure that the line of sight is free from obstruction, press to clear the "Timeout" display and re-start the measurement.

3) After distance measurement has been performed and stopped, the Recall key can be used to display the following data:

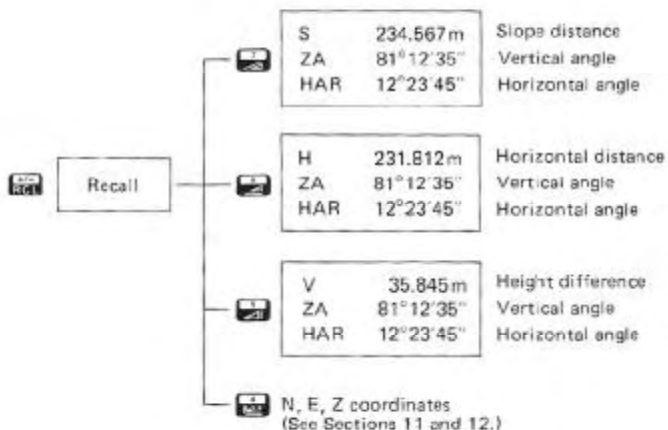

Each distance value displayed is the result calculated from the most recent measurement.

(To return to theodolite mode, press .)

11. PREPARATION FOR COORDINATE MEASUREMENT

The SET4B calculates the 3-dimensional coordinates of the prism position. To calculate the Z (Height) coordinate, first enter the instrument and target heights, then the instrument station coordinates.

By entering the Backsight station coordinates, sighting the backsight station and pressing a key on the SET4B keyboard, the horizontal angle can be set to the azimuth value.

11.1 INPUT OF INSTRUMENT AND TARGET HEIGHTS

Press function keys
to select operation



1. Set value
2. Config



1. AZ S-O ang
2. Instr Ht
3. Target Ht



Instrument
0.000m

< Input value >

1. AZ S-O ang
2. Instr Ht
3. Target Ht



1) From the SET4B Basic mode, press to enter the Menu mode. "MENU" is displayed in the small display.

2) Select the "1. Set value" option by pressing .

3) To input the Instrument height value, press to select the "2. Instr Ht" option.

4) Input the instrument height value and press to enter it in the memory, e.g. To input a height of 1.567 m, input



The display returns to the Set value menu.

5) To input the Target height value, press to select the "3. Target Ht" option.

Target
 0.000m

< Input value > 

1. AZ S-O ang
 2. Instr Ht
 3. Target Ht



1. Set value
 2. Config





Press function keys
 to select operation

6) In the same way as described in part 4), input the target height value and enter it in the memory.

The display returns to the Set value menu.

7) Press  (exit) to return to the main menu display.

8) Press  again to exit from the Menu mode to the Basic mode ("Press function keys..." displayed).

- Entered data should be between -9999.999 and +9999.999.
- The instrument and target height values remain in the memory for about a week after the instrument power is switched off.
- During data entry, press  to clear a displayed value.



11.2 INPUT OF INSTRUMENT STATION COORDINATES

Press function keys
 to select operation

 + 

ST  0.000
 E 0.000
 Z 0.000

< Input N-coord > 

1) From the SET4B Basic mode, press  +  to enter the instrument station coordinate setting display. Previously-entered coordinate values are displayed, and the cursor flashes beside the N-coordinate.

2) Input the N-coordinate value and press  to enter this value in the memory. The cursor moves to the E-coordinate.

< Input E-coord > 

< Input Z-coord > 

Press function keys
to select operation

3) In the same way, input and enter the E and Z-coordinate values in the memory. The display returns to the Basic mode.

- The instrument station coordinates are stored in the memory for about a week after the SET4B is switched off.
- The entered data should be between -9999.999 and +9999.999.
- During data entry, press  to clear a displayed value.

11.3 INPUT OF BACKSIGHT STATION COORDINATES

Press function keys
to select operation

 + 



BS		0.000
	E	0.000
	Z	0.000

< Input N-coord > 

< Input E-coord > 

< Input Z-coord > 

Press function keys
to select operation

1) In the SET4B Basic mode, press  +  to enter the Backsight station coordinate setting display. Previously-entered backsight station coordinate values are displayed and the cursor flashes on the N-coordinate position.

2) Input the N-coordinate value and press  to enter the value in the memory. The cursor moves to the E-coordinate position.

3) In the same way, input and enter the E- and Z-coordinate values. The display returns to the Basic mode.

- The entered values remain stored in the memory of the SET4B for about a week after the instrument is switched off.
- Entered values should be between -9999.999 and +9999.999.
- During data entry, press  to clear a displayed value.

11.4 SETTING THE AZIMUTH ANGLE FROM THE INSTRUMENT AND BACKSIGHT STATION COORDINATES

After input of the Instrument and Backsight station coordinates, the SET4B can calculate the azimuth angle and can set this value to the horizontal angle.

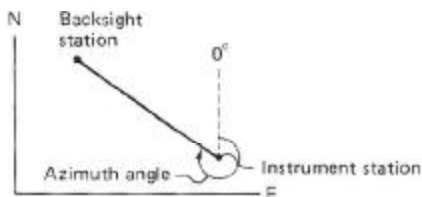

Press function keys
to select operation

ENT + $\frac{\text{P}}{\text{100}}$

Calculating

ZA 81°38'45"
HAR 304°20'10"

ENT

Press function keys
to select operation

1) With the SET4B set up over the Instrument station and in the Basic mode, sight the Backsight station,

2) Press ENT + $\frac{\text{P}}{\text{100}}$ to calculate and set the azimuth angle to the horizontal angle. "Calculating" is displayed during calculation.

The SET4B returns to the Angle measurement mode and displays the vertical and horizontal (azimuth) angle.

3) Press ENT to return to the Basic mode ("Press function keys . . ." displayed).

Note: If the azimuth angle is already known, it can be input directly using the "Set the horizontal angle to a required value" procedure described on page 14.

12. COORDINATE MEASUREMENT

12.1 3-DIMENSIONAL COORDINATE MEASUREMENT

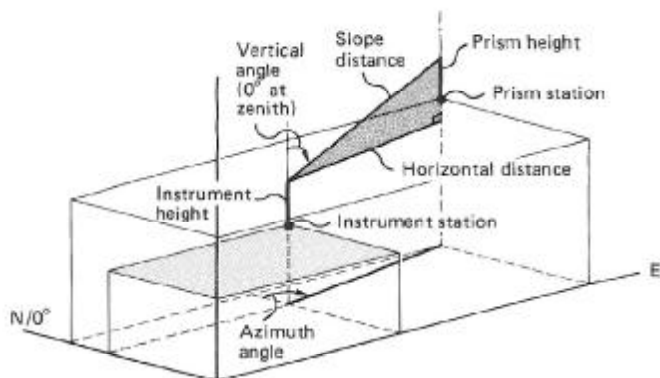

The following formulas are used for calculation of the 3-dimensional coordinates:

$$N\text{-coordinate} = N_0 + S \times \sin \theta_Z \times \cos \theta_H$$

$$E\text{-coordinate} = E_0 + S \times \sin \theta_Z \times \sin \theta_H$$

$$Z\text{-coordinate} = Z_0 + Mh + S \times \cos \theta_Z - Ph$$

where:

N_0, E_0, Z_0 : Instrument station coordinates

S: Slope distance

θ_Z : Vertical angle (0° at zenith)

θ_H : Azimuth angle

Mh: Instrument height

Ph: Prism height

- When measuring 3-dimensional coordinates, it is first necessary to enter the Instrument and prism heights, Instrument and Backsight station coordinates and calculate or input the azimuth angle (see previous pages).

Press function keys
to select operation

- 1) Sight the centre of the reflecting prism.
- 2) From the SET4B Basic mode, press



-Coordinate-

N	123.456
E	345.678
Z	34.567

"Coordinate" is displayed during measurement.

After 6 seconds (fine measurement mode), the N-, E- and Z-coordinate values are displayed.

- 3) In the repeat and tracking measurement modes, press **MEM** to stop the coordinate measurements. (In single measurement mode, this step is unnecessary.)

12.2 TRAVERSE-STYLE COORDINATE MEASUREMENT

At the first survey station, after entry of Instrument and Prism heights and Instrument and Backsight station coordinates, set the azimuth angle from the Instrument and Backsight coordinates and then measure the 3-dimensional coordinates of the next survey station. Switch off the SET4B and move it to the next station and set it up. By sighting back on the first survey station and pressing a key on the SET4B keyboard, the new Instrument station coordinates and azimuth angle are set in the instrument.

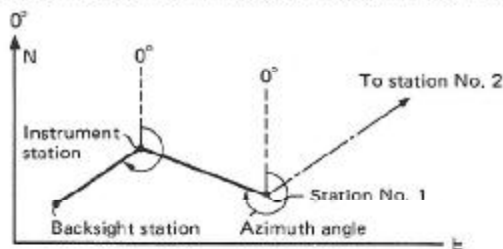

- 1) From the SET4B Basic mode, enter the Instrument and Prism heights and Instrument and Backsight station coordinates. Then set the azimuth angle from the Instrument and Backsight station coordinates. (See Sections 11.1, 11.2, 11.3, 11.4.)

Press function keys
to select operation



Stn pt replace?
Yes/No (Exit)



Replaced



ZA 88°12'35"
HAR 291°23'45"



- 2) From the Instrument station, measure the 3-dimensional coordinates of Station No. 1. (See Section 12.1.)
- 3) Switch the SET4B off, and move the instrument to station No. 1 and set it up over the survey point.
- 4) From Station No. 1, sight back on the original instrument station.
- 5) In the SET4B Basic mode, press **F1** + **F2** to set the new instrument station coordinates and azimuth angle in the instrument. The instrument asks whether the new station coordinates are to replace the previously-stored ones.
- 6) To set the new instrument station coordinates, press **F3**.

The display shows "Replaced" to signify that the coordinates of station No. 1 have been set in the instrument. The instrument then calculates and sets the azimuth angle and returns to the theodolite mode.

13. REMOTE ELEVATION MEASUREMENT

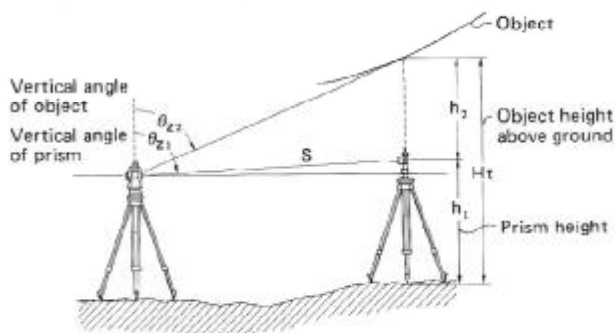
When measuring the height of certain objects such as overhead power cables where the reflecting prism cannot usually be positioned, the Remote elevation measurement function can be used to calculate the height above the ground using a point directly above or below the object.



- 1) Set up the reflecting prism directly above or below the object to be surveyed using an optical nadir or plummet for accurate setting.
- 2) Measure the prism height above the ground and input it into the SET4B by using the "Target Ht" option in the Menu mode. See page 25 for procedures for entering the Target height value.
- 3) Sight the centre of the prism with the SET4B and, in Basic mode, press the  key to measure the slope distance. Press  to stop the measurement, if necessary. (For slope distance measurement procedures, see page 23.) The measured values are stored in the instrument memory.

Press function keys
to select operation



S	234.567m
ZA	81°12'35"
HAR	12°23'45"

4) Accurately sight the object.



5) Press to measure the object height above the ground.

Ht	16.290m
ZA	77°11'10"
HAR	12°23'45"

After 1 second, the object height above the ground is displayed.

6) Press to stop the measurement.

Note that the vertical angle limit for this function is $\pm 89^\circ$ from the horizontal, and the Ht value limit is ± 9999.999 m (± 32808.33 ft).

14. MISSING LINE MEASUREMENT

This function allows the calculation of the slope distance, horizontal distance and height difference between the starting position (P_1) and any other points. It is also possible to change the starting position to that of the last-measured point.

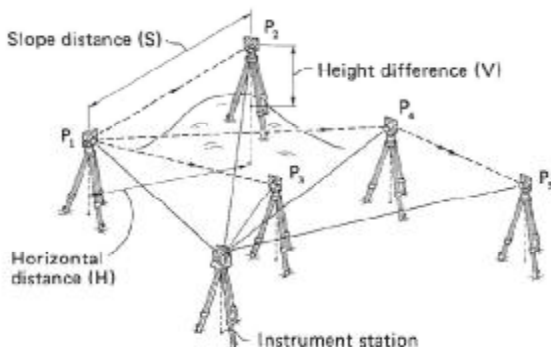

Press function keys
to select operation



S	234.567m
ZA	81°12'35"
HAR	12°23'45"



Missing line

S	276.890m
H	234.567m
V	89.012m

- 1) Set up the reflecting prisms on the required number of target positions.
- 2) Sight the first prism P_1 (starting position) and, from the Basic mode, press to measure the slope distance. (For full description of slope distance measurement, see page 23.) Press to stop the measurement, if necessary. The measured values are stored in the instrument memory.

- 3) Sight prism P_2 and press to start the missing line measurement. "Missing line" is displayed while the SET4B performs the measurement.

After about 6.5 seconds (fine measurement mode), the Slope distance (S), Horizontal distance (H) and Height difference (V) between points P_1 and P_2 are displayed.

- 4) Press **END** to stop the Missing line measurement, if necessary.
- 5) To continue the missing line measurement between P_1 and other points, sight each reflecting prism in turn and press **END** to start the measurement.

Change of starting position

The starting position (P_1) can be changed to the last-measured position (e.g. P_4), by pressing **END** + **0 SET**. Only the last-measured point can be used in this procedure.

S	231.812m
ZA	81°12'35"
HAR	12°23'45"

END + **0 SET**

Point replace?
Yes/No (Exit)

END

Replaced

↓
Press function keys
to select operation

- 6) After measurement to the prism point (e.g. P_4), press **END** + **0 SET** to use this point as the new starting point. The instrument asks whether the last-measured point is to be used to replace the original starting point.
- 7) Press **END** to set the new starting point. The display of "Replaced" confirms that the new starting point has been set. The display then returns to the Basic mode.
- 8) To continue measurement between the new starting point and other prisms, sight each prism in turn and press **END**.

15. SETTING OUT MEASUREMENT

In Setting out measurement, the instrument displays the difference between previously-entered setting out data and the measured value. In the SET4B, it is possible to set out a horizontal angle, distance, remote elevation measurement or coordinates.

15.1 HORIZONTAL ANGLE SETTING OUT MEASUREMENT

Press function keys
to select operation



1. Set value
2. Config



1. AZ S-O ang
2. Instr Ht
3. Target Ht



AZ S-O ang
HAIR: 0°00'00"

< Input angle >

1. AZ S-O ang
2. Instr Ht
3. Target Ht



Entry of the horizontal angle value to be set out.

- 1) In Basic mode, press to enter the Menu mode.
The menu options are displayed.
- 2) Press to select the "Set value" option. The Set value options are displayed.
- 3) Press to select the "AZ S-O ang" option. The previously-entered horizontal angle setting out value is displayed.
- 4) Input and enter the horizontal angle setting out data using the SET4B keyboard.
e.g. To enter a value of 123°45'55"
Press

Press function keys
to select operation



Stakeout



dHA 3°45'55"
HAR 120°00'00"

Horizontal angle setting out

6) Press the (setting out) key. "Stake-out" is displayed.

7) Press to start the Horizontal angle setting out measurement and sight the target.

The setting out data is displayed as follows:

dHA: Setting out data -
Measured horizontal angle value
HAR: Measured horizontal angle

When dHA becomes 0°00'00", the target is on-line.

- The dHA value is displayed $\pm 180^\circ$.
- The entered setting out data should be between 0° to 359°59'55".
- The data is stored in the memory for about a week after power off.
- Press to clear a displayed value during data entry.
- Press to return to basic mode after completion of setting out.

15.2 DISTANCE SETTING OUT MEASUREMENT

In distance setting out mode, it is possible to set out a slope distance, horizontal distance, height difference or remote elevation value after inputting the required value.

Press function keys
to select operation



S-O distance
D 0.000m

Entry of distance value to be set out

1) In Basic mode, press + to enter the distance setting out data display. The previously-entered distance setting out value is displayed.

< Input distance >



Press function keys
to select operation

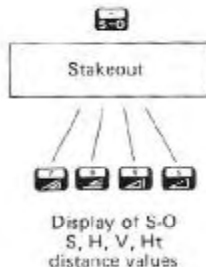

Press function keys
to select operation

2) Input and enter the distance setting out data using the SET4B keyboard.

e.g. To enter a value of 123.456m,

Press

(Entered values must be between -9999.999 and +9999.999.)

The display returns to the Basic mode.

Distance setting out

- 3) Sight the reflecting prism.
- 4) Press to enter the Setting out mode, "Stakeout" is displayed.
- 5) Press: for slope distance setting out,
 for horizontal distance setting out,
 for height difference setting out,
 for remote elevation setting out (after slope distance measurement).

After measurement, the setting out values are displayed as follows:

Displayed value
= Measured value - Setting out value

When the value becomes 0.000, the distance has been set out.



6) Press to return to Basic mode.

15.3 COORDINATES SETTING OUT MEASUREMENT

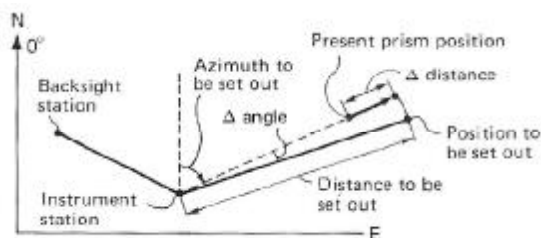
In coordinates setting out measurement, after entry of instrument and Prism heights and Instrument and Backsight station coordinates and setting the azimuth angle, input the coordinates of the point to be set out. The SET4B calculates the setting out horizontal angle and horizontal distance and stores the values in the memory. By selecting the horizontal angle and then the horizontal distance setting out functions, the required coordinate location can be set out. The Z-coordinate can also be set out using the setting out coordinate function.



1) From the SET4B Basic mode, enter the Instrument and Prism heights and Instrument and Backsight station coordinates. Then set the azimuth angle from the Instrument and Backsight station coordinates. (For procedures, see Sections 11.1, 11.2, 11.3 and 11.4.)

2) From the SET4B Basic mode, press  +  to input and enter the coordinates of the point to be set out. Previously-entered setting out coordinate values will be displayed and the cursor flashes at the N-coordinate position.

Press function keys
to select operation





P	N	0.000 m
	E	0.000 m
	Z	0.000 m

< Input N-coord > 

< Input E-coord > 

< Input Z-coord > 

Press function keys
to select operation

 + 

< Set out horizontal
angle >

dHA	0°00'00"
HAR	127°43'30"



Press function keys
to select operation

 + 

< Set out horizontal
distance >

H	0.000m
ZA	81°12'35"
HAR	127°43'30"





Press function keys
to select operation

3) Input the N-coordinate of the point to be set out and press  to enter it in the memory.



4) In the same way, input and enter the E- and Z-coordinates. The instrument calculates the setting out horizontal angle and horizontal distance values, stores them in the AZ S-O and distance S-O memories, then returns to the Basic mode display.

Note: Always perform the procedures in the above order or the calculation may not be correctly done.

5) Press  +  to set out the horizontal angle. The display shows the angle between the prism position and the position to be set out.

6) When the displayed setting out angle value becomes 0°, the prism is on-line.

7) Press  to return to Basic mode.



8) Press  +  to set out the horizontal distance. The display shows the distance between the prism position and the position to be set out.

9) When the displayed setting out distance value becomes 0m, and the angle setting out value is still 0°, the prism is directly over the point to be set out. Press  to return to the Basic mode.

 + 

6
-30
SOI+

N	0.000m
E	0.000m
Z	0.000m

To set the prism to the required height (Z-coordinate), press  +  to start the setting out coordinates measurement.

The N- and E-coordinate values should already be zero, therefore move the prism up or down at the correct N, E position until the ΔZ value is zero.

When the ΔN , ΔE and ΔZ values are all zero, the point has been set out at the required 3-dimensional coordinate position.

16. INSTRUMENT PARAMETER SETTINGS

16.1 ENTRY TO PARAMETER SETTING MODE

Press function keys
to select operation



1. Set value
2. Config



- ◆ Recording
- Out Code Tgt ht

1) From the SET4B Basic mode, press to enter the MENU mode. "MENU" is displayed in the small upper screen.

2) Press to select "2. Config" to enter the Config (Instrument parameter setting) mode. The first parameter "Recording" is displayed.

- The "◆" symbol means that the and keys can be used to move up and down through the parameters.
- The parameter options currently selected are displayed on the bottom line of the screen.

In Parameter setting mode:

- To move to the previous parameter, press .
- To move to the next parameter, press .
- To change the parameter options, press . The parameter options are displayed.

Press to select option No. 1.

Press to select option No. 2.

Press to select option No. 3.

After selection of the options, the display returns to the parameter display. The selected option is displayed on the bottom line of the screen. Each time the instrument parameter options are changed, the new settings replace the previous settings stored in the permanent memory.

- To exit from the option or parameter displays, press . The previously-stored values are retained in the memory. Continue to press to return to the Basic mode.

16.2 SUMMARY OF PARAMETER OPTIONS

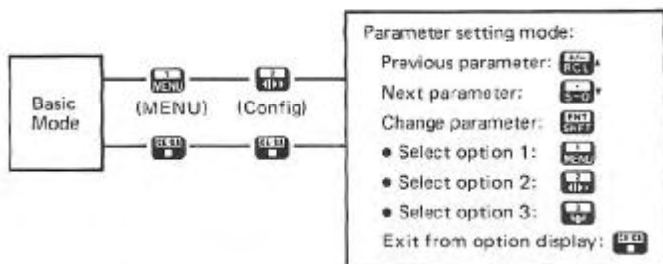

Parameter	Options
Recording	1. Set code (*1. Set 2. Skip) 2. Set target Ht (*1. Set 2. Skip)
Audio for return signal	*1. On 2. Off
Reticle illumination	*1. Bright 2. Dim
Backlight control	*1. On/Off by key operation 2. 30 seconds timeout
Auto power off	*1. 30 minutes timeout 2. Power On/Off with switch
Distance units	*1. Metres 2. Feet
C & R correction	*1. None 2. Applied, K = 0.142 3. Applied, K = 0.20
Temp & Pressure units	*1. °C + mbar 2. °C + mmHg 3. (1. °F + mbar 2. °F + mmHg 3. °F + inchHg)

Parameter	Options
Angle units	*1. Degrees 2. gon
Angle resolution	*1. 5" (1mgon) 2. 10" (2mgon)
V angle format	*1. Zenith 0° 2. Horizontal 0°–360° (0–400gon) 3. Horizontal ±90° (±100gon)
Tilt correction	*1. Yes 2. No
V indexing	*1. Auto 2. Manual
H indexing	*1. Auto 2. Manual
RS-232C format	1. Baud rate (*1. 1200 2. 2400) 2. Checksum (*1. Yes 2. No) 3. Parity bit (*1. No 2. Even)
Configuration default set:	Initialize: Yes/No

* Parameter options set at time instrument left the factory. These options are reset when "Configuration default set" is initialized.

16.3 CHANGING INSTRUMENT PARAMETER OPTIONS

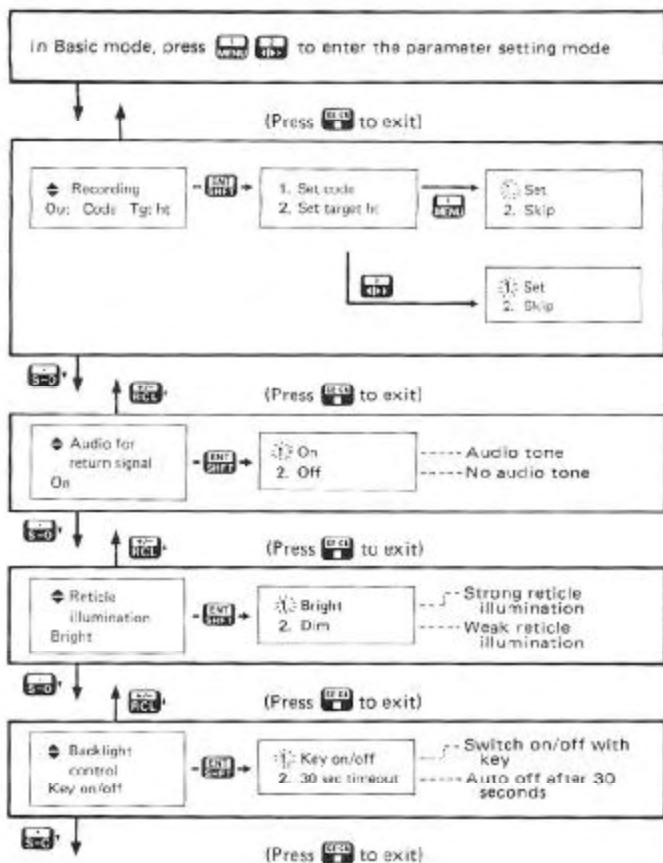

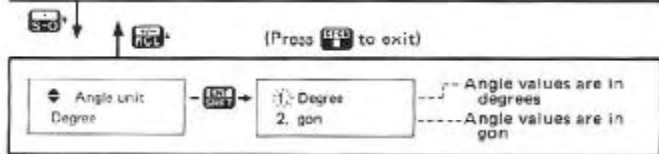
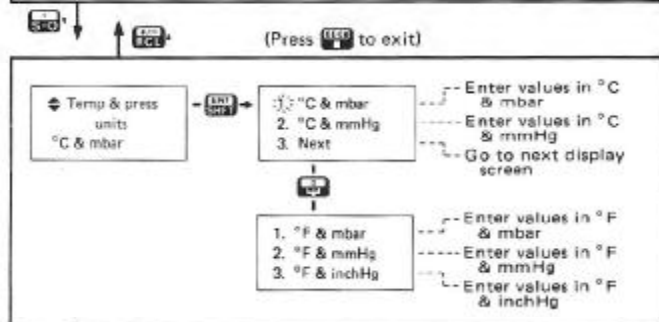
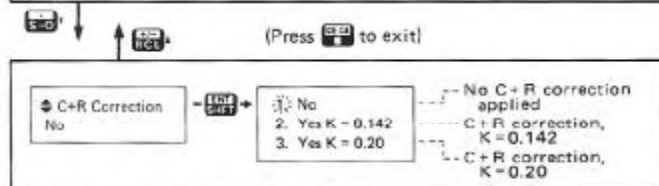
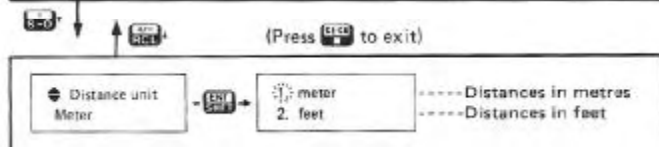
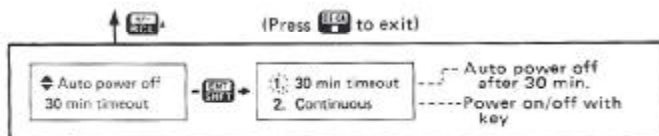

(Press **ESC** to exit)

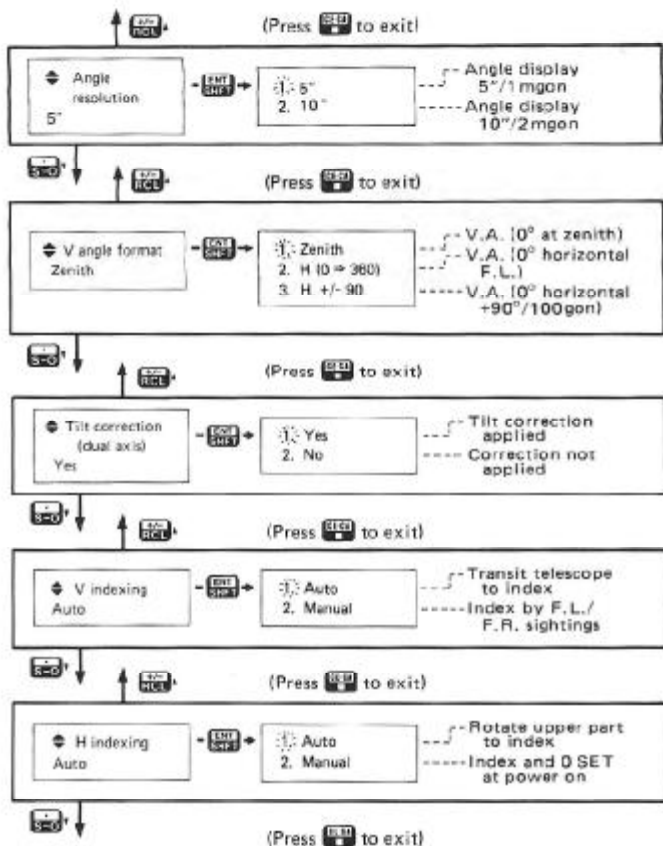

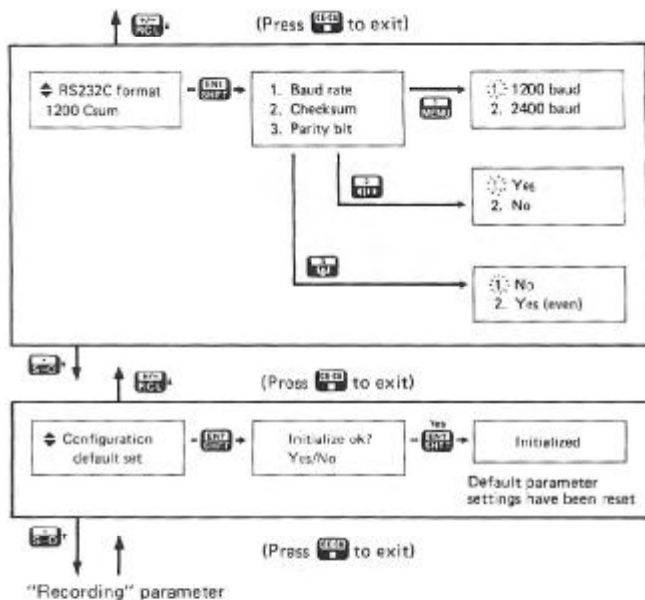

17. DATA RECORDING ON AN EXTERNAL DEVICE

Instrument and measured data can be output to an external device using the SET4B keyboard. Items which can be recorded include: Instrument identification (Name, Serial number and Program software version), Station point data (Date, Station point No., Optional point code, instrument height, Atmospheric correction, Instrument N-, E- and Z-coordinates and Instrument parameters), and Measured point data (In various data formats with point number and optional point code and target height inputs).

Instrument parameters: See page 42—.

The “Recording” parameter can be used to select the data recording options.

These options are: 1. Input (1) or non-input (2) of target point code description, and 2. Input (1) or non-input (2) of target height for each measured point.

Press function keys
to select operation





External device



◆ Select format:
S-V-H
Record?: Yes/No

- 1) In the SET4B Basic mode, press  to enter the REC. (data recording) menu. “REC” is displayed on the small upper display, and the main display briefly shows that the data is being output to an external device.



Select data format/Record data display

- Select the format of the data to be recorded, using the  and  keys.
- Measure and record the data using .

1. Select data format (not necessary if required data format is displayed)

The displayed data format i.e. S, V, H can be changed, if required, using the  and  keys.

The options available are:

	S, V, H	Measure and record the target Slope distance, vertical and horizontal angles
↓	V, H, Tilt	Measure and record the target vertical, horizontal and tilt angles
	N, E, Z	Measure and record the target North, East and Elevation coordinates
	N, E, Z + S, V, H	Measure and record the target North, East and Elevation coordinates and Slope distance, vertical and horizontal angles
↑	Stn point data	Input and record station point data (See page 53.)
	Instr ID	Record Instrument ID data (See page 55.)

2. Record the data

- ① For **S, V, H**, **V, H, Tilt**, **N, E, Z**, and **N, E, Z + S, V, H** formats:

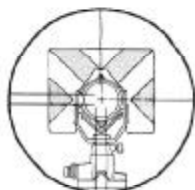

- 1) Sight the centre of the prism or target.

◆ Select format:
S, V, H
Record?: Yes/No



- 2) Press **YES** to start the data recording.
(During the data entry and recording procedure, to exit press **ESC**.)

Target point
No. 1001



(Or input point
No., then **SET**)

- 3) Enter or confirm the target point number. The number displayed is the last measured point number +1. To confirm this point number, press **SET**. To enter a new point number (between 1 and 9999), use the SET4B keyboard numerical keys to input the point number, then press **SET**.
- If the "Set code" and "Set target Ht" parameters have been set to "Skip", the SET4B measures and displays the selected data. (See 6) below.)

< Optional code entry >

- 4) If the "Recording" parameter "Set code" option is "Set", input the required code using the **[F10]**, **[F9]** and numerical keys as follows:

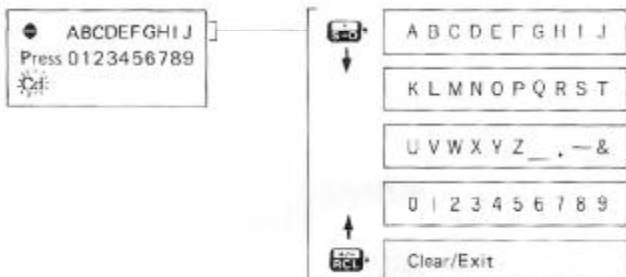

- Use the **[F10]** and **[F9]** keys to select the required block of characters: A–J, K–T, U–&, 0–9, or Clear/Exit.
- Press the numerical key corresponding to the required character, i.e. To select Z: (1) Select block U–& using **[F10]**, **[F9]** - (2) Press **[Z]** to select "Z".

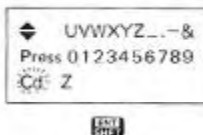

Press **[ENT]** to enter the point code.

- Point codes can be up to 20 characters long and can be used to describe the target feature.
e.g. TREE_SIZE_10
- The last-entered code value is stored in the memory and is displayed when the next code is to be entered.
- To delete one character to the left, press **[DEL]**.
- To clear the displayed code for re-entry, select the Clear/Exit option using **[F10]**, **[F9]** and press **[ENT]**. To exit, press **[ENT]** again.

< Original target height entry >

Input target
Ht: 1.5

**END
SHIFT**

Target No. XXXX
Record end

5) If the "Recording" parameter "Set target Ht" option is "Set", input the target Ht value and press **END SHIFT**.

6) The SET4B measures and displays one set of the target point data in the selected format.

The measured values flash while the data is being recorded, then "Target No. XXXX, Record end" is displayed to show that the data has been successfully recorded. The display returns to the "Select format/Record" display.

- If there is some problem with the measured data, "Data error" is displayed and the data will not be recorded.
- If there is some problem with the data communication, the data error display "Record error" will be displayed and the data will not be recorded.

② For **Stn point data** format:

◆ Select format:
Stn point data
Record?: Yes/No

**Yes
SHIFT**

Date yy.mm.dd
89.11.20

< Enter date > **END
SHIFT**

Stn point
No: 3

< Enter Stn No. > **END
SHIFT**

1) Press **Yes SHIFT** to start the data recording. (During the data entry and recording procedure, to exit, press **END SHIFT**.)

The display prompts for the entry of the date in the format "yy.mm.dd" (Year,Month,Day).

Enter or confirm the date using the **END SHIFT** key.

2) The display asks for the entry or confirmation of the station point number. The number displayed is the previous station point number +1.

Press **END SHIFT** to confirm this number (or input a station number (between 1 and 9999) and enter it with **END SHIFT**).

< Optional code entry >



< Enter Ht > 

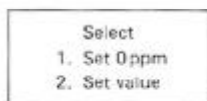





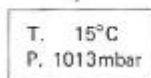

0ppm
Set

Input temp 

Input press 

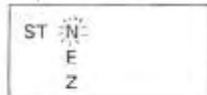

< Enter N-coordinate > 



< Enter E-coordinate > 

< Enter Z-coordinate > 



3) If the "Recording" parameter "Set code" option is "Set", input the required code as described in 4) on page 52.

4) The display requests the instrument height value. Enter or confirm the instrument height using the  key.

5) The display now asks for the input of the atmospheric correction value. As in Section 9.2 on page 18, input  to set 0ppm, which is recorded as a temperature and pressure value, or press  then input the temperature and pressure, pressing  to enter each value.

6) The display asks for the confirmation or input of the station N-, E- and Z-coordinates. Confirm or enter the coordinate values, pressing  to enter each value.

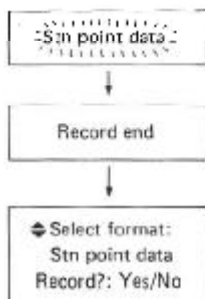

After entry of the Z-coordinate value, the display flashes "Stn point data" while the data is being recorded, then "Record end", and the display returns to the "Select format" display.

- If there is some problem with the data communication, the data error display "Record error" will be displayed and the data will not be recorded.

③ For **Instr ID** format:

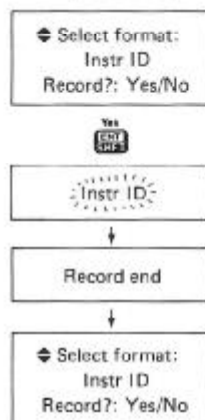

- 1) Press  to start the data recording. The display flashes "Instr ID" while the data is being recorded, then "Record end" and the display returns to the "Select format" display.
- If there is some problem with the data communication, the data error display "Record error" will be displayed and the data will not be recorded.

18. CHECKS AND ADJUSTMENTS

It is important that the SET4B is periodically checked and adjusted. In addition, the instrument should be checked after transportation, long storage or when damage to the instrument is suspected to have occurred. The checks should be performed as follows:

18.1 ANGLE MEASURING FUNCTION

18.1.1 Plate level

18.1.2 Circular level

18.1.3 Reticle adjustments

- Perpendicularity of the reticle to the horizontal axis
- Vertical and horizontal reticle line positions

18.1.4 Coincidence of the distance measuring axis with the reticle

18.1.5 Optical plummet

18.1.1 Plate level

The glass tube of the plate level is sensitive to temperature change or shock. Be sure to check the plate level  before use.

- See the figures below for relation between bubble movement and rotation of the levelling screws.

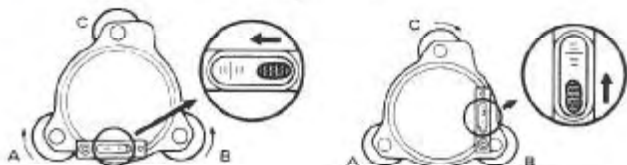

- Turn the upper part of the SET4B until the plate level is parallel to a line between levelling screws A and B. Then centre the bubble using levelling screws A and B.

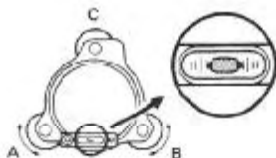

- 3) Turn the upper part 90° (100 gon) until the plate level is perpendicular to a line between levelling screws A and B. Then centre the bubble by turning levelling screw C.

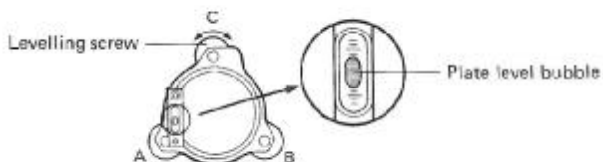

- 4) Turn the upper part 180° (200 gon). Correct any bubble deviation by half the amount with levelling screw C.

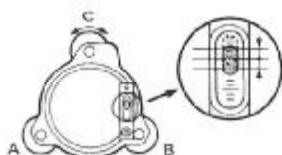

- 5) Correct the remaining half deviation by turning the plate level adjusting screw $\text{\textcircled{2}}$ with the adjusting pin.

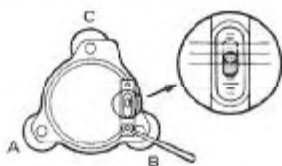

- 6) Repeat 2) to 5) above until the bubble remains in the same position for any position of the upper part.

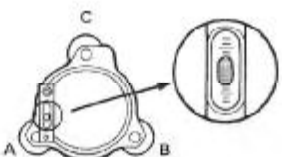

18.1.2 Circular level

When the plate level adjustment is complete, the circular level ⑨ should be checked. Note the direction off-centre of the bubble. Loosen the adjusting screw ⑩ farthest from that direction and tighten the other adjusting screws to centre the bubble. Ensure that the tension of each screw tightening is the same after adjustment.



18.1.3 Reticle adjustments

a) Perpendicularity of the reticle to the horizontal axis

- 1) Select and sight a clear target on the upper part A of the vertical reticle line.
- 2) Turn the telescope slowly upward with the vertical fine motion screw ⑭ until the target slides to the lower part B. If the target is still centrally within the vertical lines, no adjustment is necessary. If necessary, adjust as follows.

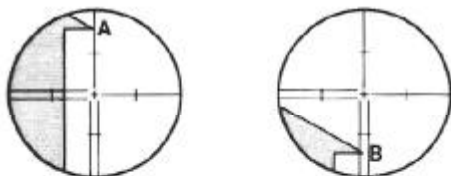

- 3) Unscrew the reticle cover ⑮.
- 4) Slightly loosen one vertical and one horizontal adjusting screw by a certain amount.
- 5) Place a small piece of plastic or wood against one side of the top adjusting screw as a buffer.
- 6) Look through the eyepiece and gently tap the piece of plastic or wood to rotate the reticle slightly.

- 7) Re-tighten the two adjusting screws (loosened in 4)) by the same amount. Check the reticle perpendicularity again and readjust if necessary. Replace the reticle cover .



b) Vertical and horizontal reticle line positions

When the index error adjustment is complete, the position of the reticle should be checked.

- 1) Level the SET4B. Select a clear target at a horizontal distance of 50 to 100m.

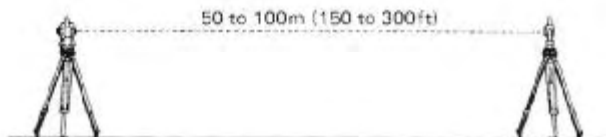

- 2) After indexing the vertical circle, sight the target and take the horizontal angle reading in face left (V1), e.g. $a_l = 18^\circ 34' 00''$ ($a_l = 20.630$ gon) and the vertical angle reading, e.g. $b_l = 90^\circ 30' 10''$ ($b_l = 100.559$ gon).

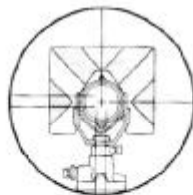

3) Next, in face right (V2), sight the same target. Take the horizontal angle reading, e.g. $a_r = 198^\circ 34' 10''$ ($a_r = 220.633$ gon) and the vertical angle reading, e.g. $b_r = 269^\circ 30' 00''$ ($b_r = 299.444$ gon).

4) Calculate $a_r - a_l$, $b_r + b_l$.

$$a_r - a_l = 198^\circ 34' 10'' - 18^\circ 34' 00'' = 180^\circ 00' 10''$$

$$(a_r - a_l = 220.633 \text{ gon} - 20.630 \text{ gon} = 200.003 \text{ gon})$$

$$b_r + b_l = 269^\circ 30' 00'' + 90^\circ 30' 10'' = 360^\circ 00' 10''$$

$$(b_r + b_l = 299.444 \text{ gon} + 100.559 \text{ gon} = 400.003 \text{ gon})$$

5) When the reticle is in the normal position, your results should show that $a_r - a_l$ is within $20''$ (0.006 gon) of 180° (200 gon) and $b_r + b_l$ is within $20''$ (0.006 gon) of 360° (400 gon). If the difference of $a_r - a_l$ from 180° (200 gon) or $b_r + b_l$ from 360° (400 gon) is $20''$ (0.006 gon) or greater after several checks, adjust as follows:

6) While still in face right (V2), use the horizontal and vertical fine motion screws to adjust the lower display, a_c , and the upper display, b_c , to read:

$$a_c = \frac{a_l + a_r}{2} + 90^\circ$$

$$b_c = \frac{b_r - b_l}{2} + 180^\circ$$

Example:

$$\text{If } a_l = 18^\circ 34' 00''$$

$$a_r = 198^\circ 34' 30''$$

$$b_l = 90^\circ 30' 10''$$

$$b_r = 269^\circ 30' 10''$$

$$a_c = \frac{a_l + a_r}{2} + 90^\circ = \frac{18^\circ 34' 00'' + 198^\circ 34' 30''}{2} + 90^\circ$$

$$= 198^\circ 34' 15''$$

$$b_c = \frac{b_r - b_l}{2} + 180^\circ = \frac{269^\circ 30' 10'' - 90^\circ 30' 10''}{2} + 180^\circ$$

$$= 269^\circ 30' 00''$$

7) Look through the telescope. The target is seen shifted from the vertical and horizontal reticle lines.

- 8) Remove the reticle adjustment cover ⑫.

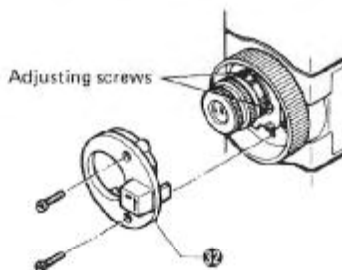

- 9) Adjust the reticle sideways with the adjusting screws until the target is centrally within the vertical lines, and then adjust it up or down with the screws until the target is centrally within the horizontal lines.

For example, to move the vertical reticle to the right (left) side, first slightly loosen the left (right) adjusting screw, then tighten the right (left) adjusting screw by the same amount. Repeat until the reticle comes close to the target centre.

In the same way, to move the horizontal reticle line down (up), slightly loosen the top (bottom) screw, then tighten the bottom (top) screw by the same amount and repeat until the reticle comes close to the target centre.

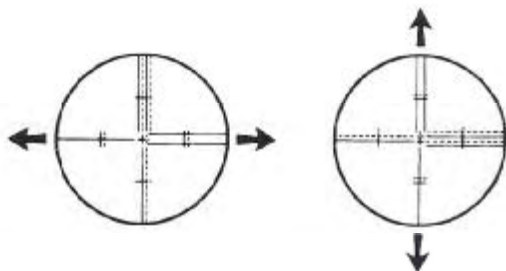

- 10) Replace the reticle adjustment cover.

This adjustment is very delicate. If you find it difficult, please contact our agent.

After this adjustment, check the coincidence of the distance measuring axis with the reticle.

18.1.4 Coincidence of the distance measuring axis with the reticle

When the reticle has been checked, check the distance measuring axis relative to the reticle as follows.

- 1) Level the SET4B. Set up the reflecting prism at a horizontal distance of 50 to 100 m (150 to 300 ft).



- 2) Sight the reflecting prism centre and take the horizontal and vertical angle readings. (H and Z respectively)

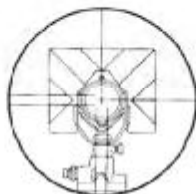

- 3) In Basic mode, press **ENT/SHIFT** + **0** on the keyboard and check that "Signal *" is displayed.

- 4) Four more readings are necessary.

Turn the horizontal or vertical fine motion screw slowly until the return signal “*” mark goes off. Then take readings.

Readings H_L, H_R : when the telescope is directed to the left (right) of the sighted direction in 2) above.

Readings Z_a, Z_b : when the telescope is directed above (below) the sighted direction in 2) above.

- 5) Check the differences of H_L (H_R) against H , and Z_a (Z_b) against Z .

When the four differences obtained are all larger than $3'$ (0.056 gon), the coincidence is normal. If the differences obtained are less than $3'$ (0.056 gon), please contact our agent.

18.1.5 Optical plummet

- 1) Level the SET4B. Centre a surveying point in the reticle of the optical plummet. Loosen the horizontal clamp and turn the upper part through 180° (200 gon). If the surveying point is still centred, no adjustment is necessary.
- 2) If the surveying point is off-centre, correct half the deviation with the four adjusting screws, and correct the remaining half with the levelling screws.



- 3) Repeat the adjustment if necessary.

18.2 DISTANCE MEASURING FUNCTION

18.2.1 Check flow chart

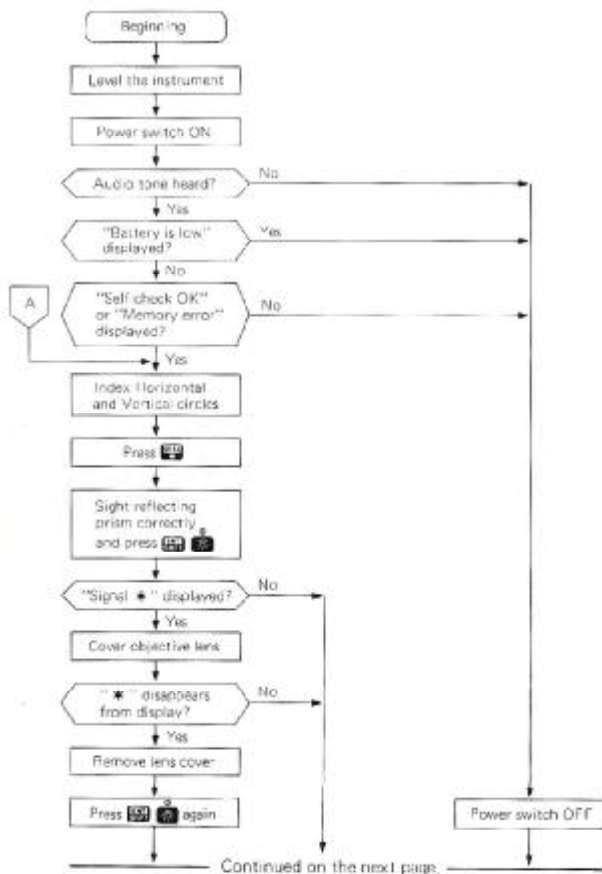

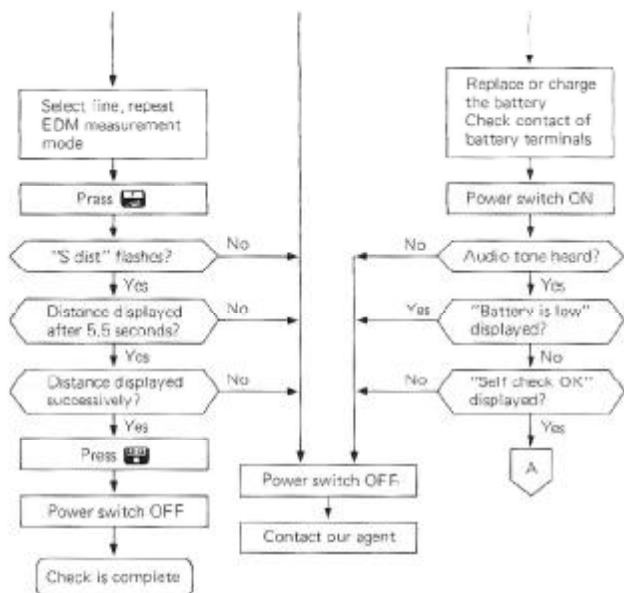

Note: If error codes EXXX are displayed, please contact your Sökkisha agent.

18.2.2 Additive distance constant

The additive distance constant of the SET4B is adjusted to 0 before delivery. However, the additive constant can change with time and so should be determined periodically and then used to correct distances measured.

1) Determining the additive distance constant,

The most reliable method of determining the additive distance constant is to test the SET4B on an established base line with a maximum range of approximately 1,000 m, and with 6 to 8 intermediate stations spaced at multiples of the instrument unit length, which is 10 m. Measurements should be taken in all combinations of the 6 to 8 stations.

If an additive distance constant of greater than 5 mm is found please contact our agent.

2) Confirmation of the additive distance constant K if a base line is not available.

a. Select points A and B on flat ground about 100 m apart, and C in the middle.

b. Set up the SET4B at A, and measure the distance AB.

Note: Be sure prism height is the same as the height of the SET4B objective lens centre. If ground is not level, use an automatic level to set correct instrument heights of all points.

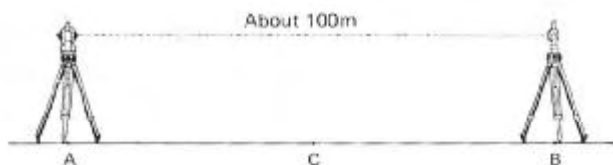

- c. Shift the SET4B to C, and measure the distance CA and CB.

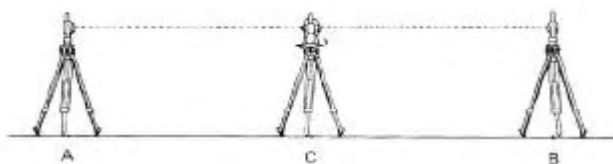

- d. Compute the additive distance error K using the formula:

$$K = \overline{AB} - (\overline{CA} + \overline{CB})$$

$\overline{AB}, \overline{CA}, \overline{CB}$: Average of ten measurements.

- e. Obtain the K value three times. If all K are greater than 5 mm, contact our agent.

19. MANUALLY INDEXING VERTICAL CIRCLE BY FACE LEFT, FACE RIGHT READINGS

Like every theodolite, the SET4B will have a vertical index error. For angle measurement of the highest accuracy, the vertical index error can be removed as follows.

- 1) From the Basic mode, press **MENU** + **OK** to enter the instrument parameters mode. Select the "V indexing" parameter and change the setting to "2. Manual" (See page 42— for more information.). Press **ESC** to exit to the Basic mode, and switch off the instrument.
- 2) Ensure that the SET4B is level, switch on the instrument and make sure that the display appears as shown below:

ZA	Face 1
HAR	0 SET

- 3) In face left (V1), accurately sight a clear target at a horizontal distance of about 30 m.

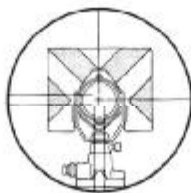

- 4) Press **BACK** and **0 SET**.

ZA	Face 2
HAR	0 SET

5) Next, in face right (V2), accurately sight the same target.

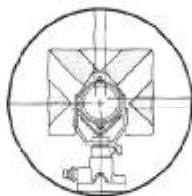

6) Press **UNIT** and **REC**. When the vertical circle is indexed, the display appears as below.

ZA	289°56'00"
HAR	0 SET

- If the power switch has been turned OFF, the vertical circle must be indexed again.
When moving the SET4B after measurement, turn the power OFF.
- Index the horizontal circle.

20. FOR DISTANCE MEASUREMENT OF THE HIGHEST ACCURACY

20.1 ACCURACY OF MEASUREMENT OF ATMOSPHERIC CONDITIONS

The relation between measured distance and the velocity of light is given by

$$D = \frac{T}{2} C = \frac{T}{2} \frac{C_0}{n}$$

T: The period between light emission and reception.

C: The velocity of light in the air.

C_0 : The velocity of light in a vacuum.

n: Refractive index of the air.

The measured distance is affected by variation in the refractive index

$$\frac{dD}{D} = - \frac{dn}{n} \approx dn \text{ (or } dD \approx D \cdot dn \text{)}$$

Therefore, the accuracy of measurement of the refractive index must be the same as that of the measured distance.

To calculate refractive index to an accuracy of 2 ppm, temperature must be measured to within 1°C and pressure to within 5 mmHg.

20.2 TO OBTAIN THE ATMOSPHERIC PRESSURE

To obtain the average refractive index of the air throughout the measured light path, you should use the average atmospheric pressure.

In flat terrain there is little variation in the atmospheric pressure. In mountains, the following calculation should be used.

Example:

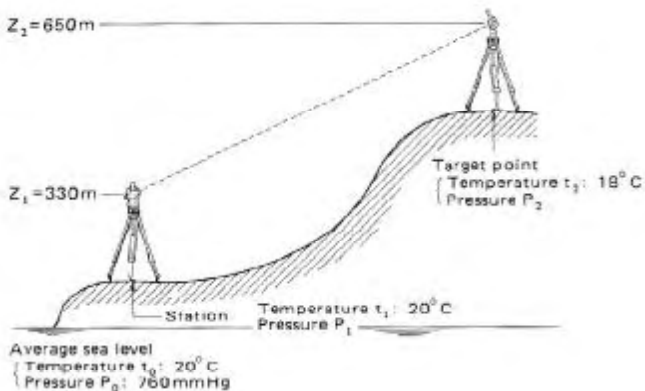

By the Laplace formula

$$Z_n - Z_0 = 18,400 \left(1 + 0.00367 \frac{t_n + t_0}{2} \right) \text{Log} (P_0/P_n)$$

t: Temperature ($^{\circ}\text{C}$)

Z: Height above sea level (m)

P: Pressure (mmHg)

$$P_n = 10^{\left\{ \text{Log} P_0 - \frac{Z_n - Z_0}{18,400 \left[1 + 0.00367 \left(\frac{t_n + t_0}{2} \right) \right]} \right\}}$$

$$P_0 = 760 \text{ mmHg} \quad Z_1 = 330 \text{ m} \quad Z_2 = 650 \text{ m}$$

$$t_0 = 20^{\circ}\text{C} \quad t_1 = 20^{\circ}\text{C} \quad t_2 = 18^{\circ}\text{C}$$

$$P_1 = 10^{\left\{ \text{Log} 760 - \frac{330}{18,400 (1 + 0.00367 \times 20)} \right\}} \approx 731$$

$$P_2 = 10^{\left\{ \text{Log} 760 - \frac{650}{18,400 (1 + 0.00367 \times 19)} \right\}} \approx 704$$

Average pressure: 717.5 mmHg

21. POWER SUPPLIES

The SET4B can be operated with the following combinations:

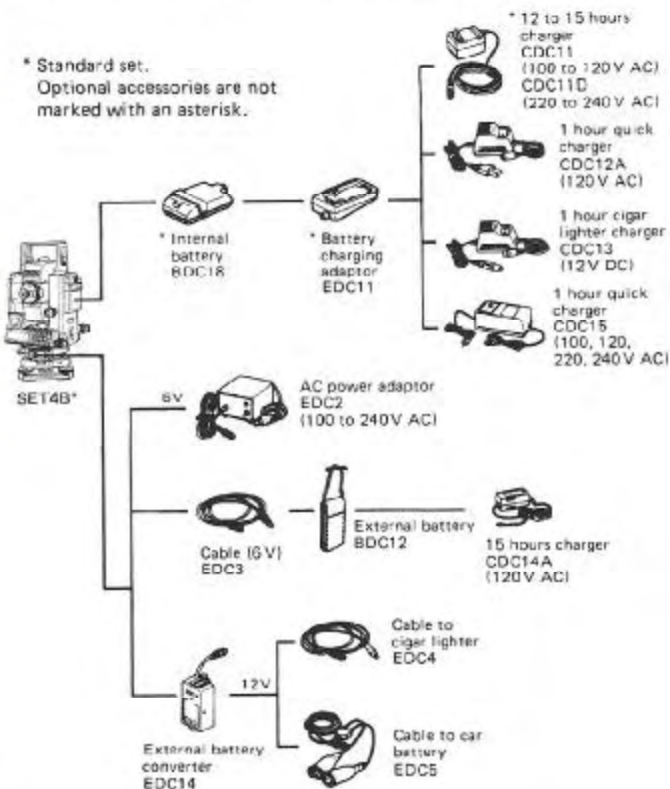

Use the SET4B only with the combinations shown here.

Note: When using the SET4B with external power supplies, it is recommended that for the most accurate angle measurements, the BDC18 battery be left in place to balance the weight on the axes.

Battery charging precautions

To charge the battery, use only the recommended charger.

- 1) Charge the battery at least once a month if it is not used for a long time.
- 2) Charge the battery at a temperature between 10°C and 40°C.
- 3) Before using EDC2 or CDC15, set the voltage selector to the proper voltage.
- 4) EDC14 has a breaker switch. Normally the red mark appears on the breaker. If not, set the red mark in place.
- 5) When using a car battery, make sure that the polarity is correct.
- 6) Make sure that the cigar lighter has 12V output and that the negative terminal is grounded.
- 7) When charging the battery, first connect it to the battery charger and then connect the charger to the power supply. Check that the battery charger light is on. If not switch power supply off and on again until the light comes on.
- 8) The battery charger may become warm while charging. This is normal.
- 9) Do not charge the battery for any longer than specified.
- 10) Store the battery in a place where the temperature is between 0°C and 40°C.
- 11) Battery operating life is shortened at extreme temperatures.

22. REFLECTING PRISMS AND ACCESSORIES

All Sokkisha reflecting prisms and their accessories have standardized screws (5/8" x 11 thread) for easy compatibility.

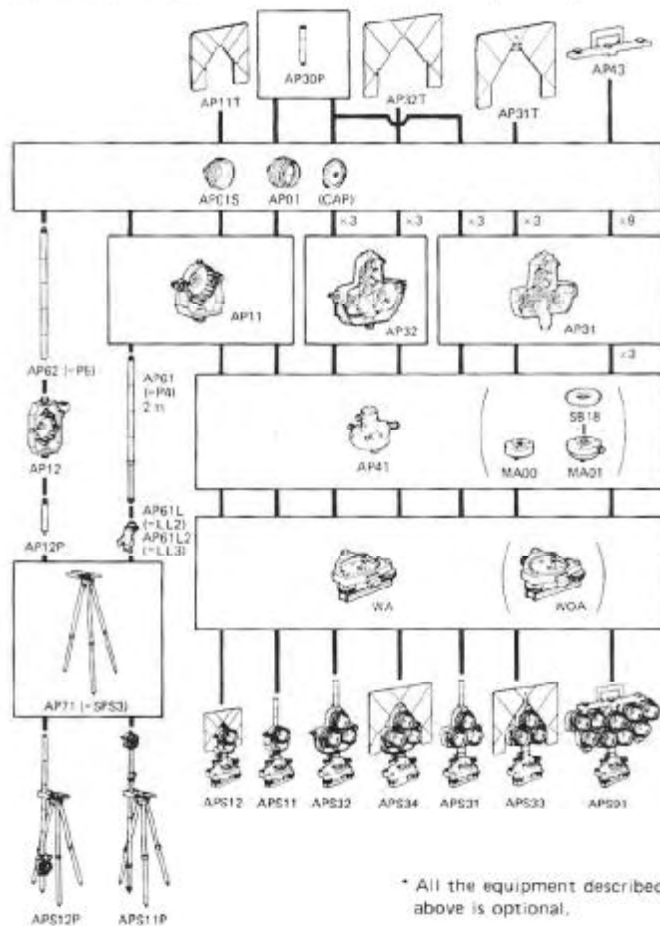

* All the equipment described above is optional.

Target fluorescent paint finishing allows clearer sighting in adverse observing conditions.

Precautions

- 1) Carefully face the reflecting prism towards the instrument; sight the target centre accurately.
- 2) To use the triple prism assembly AP31 or AP32 as a single prism (e.g. for short distances), mount the single prism AP01 in the centre hole of the triple prism holder.
- 3) Check that "236" (the height of the SET4B) is displayed in the window of the instrument height adaptor AP41.
The height of the AP41 can be adjusted as follows:
 - ① Loosen the two fixing screws,
 - ② Turn the centre part counterclockwise to unlock it.
 - ③ Move it up or down until "236" appears in the window.
 - ④ Turn the centre part clockwise to re-lock it.
 - ⑤ Tighten the fixing screws.

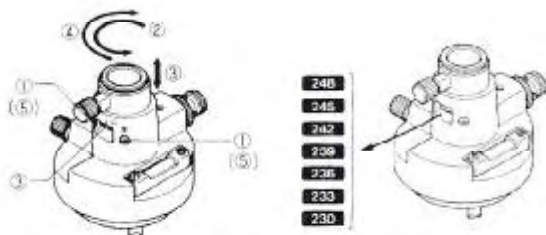

- 4) Use the plate level on the AP41 to adjust the tribrach circular level as in 18.1.2.
- 5) Check the optical plummet of the AP41 as in 18.1.5.
After all checks and adjustments have been completed, make sure that the AP41 optical plummet sights the same point as the optical plummet of the SET4B.

23. STANDARD EQUIPMENT

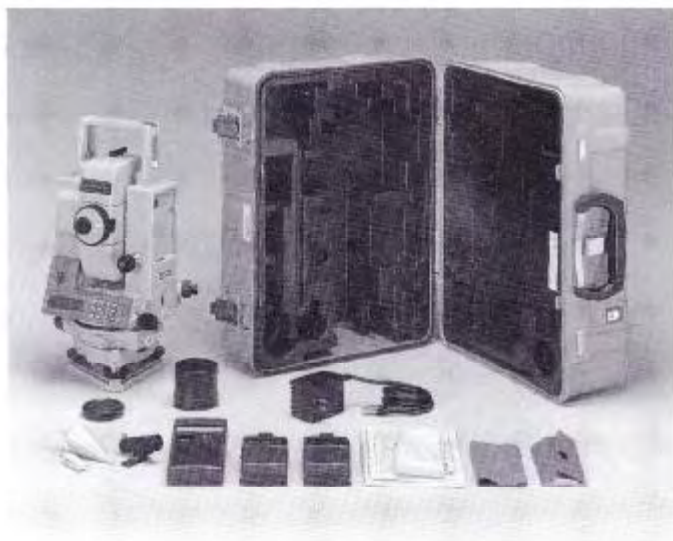

SET4B main unit	1	Vinyl cover	1
Internal battery, BDC18	2	Plumb bob	1
Battery charger, CDC11/CDC11D	1	Tool pouch	1
Battery charging adaptor, EDC11	1	Screwdriver	1
Tubular compass, CP7 (accuracy: $\pm 1^{\circ}$)	1	Lens brush	1
Lens cap	1	Adjusting pin	2
Lens hood	1	Cleaning cloth	1
		Operator's manual	1
		Carrying case, SC78	1

24. OPTIONAL ACCESSORIES

24.1 INTERFACE CABLES DOC1, DOC25/DOC26/DOC27

The interface cable DOC1 can be used for direct two-way communication between the SET4B and a host computer. This cable is not provided with a connector on the computer end of the cable.

Also available are: DOC25: NEC connector
DOC26: IBM connector
DOC27: Toshiba J3100

24.2 ELECTRONIC FIELD BOOK SDR SERIES

The SDR series collects and stores slope distance, zenith and horizontal angle data from the SET4B.

Calculations can be performed on the data so that the measurements can be verified in the field.

The stored data can be transmitted to a data processing system.



SDR series specifications

Power source:	"AA" (UM3) x 4
Memory type:	CMOS
RAM	32, 64 or 128 K
ROM	64 K
Keyboard:	33 keys
Display:	LCD
Baud rate:	300, 600, 1200, 2400, 4800, 9600 bps
Operating temperature range:	0 to 50°C (32 to 122°F)
Weight:	450 g (1 lb)

24.3 DIAGONAL EYEPiece DE18

The diagonal eyepiece is convenient for steep observations and in places where space around the instrument is limited.

Remove the eyepiece ⑩ by loosening the mounting ring, and screw in the diagonal eyepiece.

Setting up the DE18

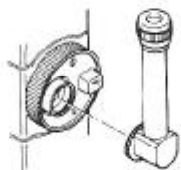

24.4 SOLAR FILTER OF1/OF1A

For observations to the sun, and where glare is present. The OF1 and OF1A (flip-up type) filters are mounted on the objective lens.

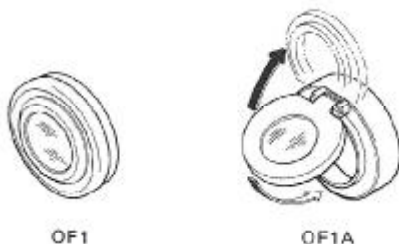

25. SPECIFICATIONS

Distance measurement

Range:

Average conditions: (Slight haze, visibility about 20 km, sunny periods, weak scintillation)

Compact prism CP01: 600 m (2,000 ft)

Standard prism APx1: 1,200 m (3,900 ft)

Standard prism APx3: 1,700 m (5,600 ft)

Standard prism APx9: 2,200 m (7,200 ft)

Standard deviation: $\pm (5 \text{ mm} + 3 \text{ ppm} \cdot D)$

Display: 2 LCD dot matrix displays; main display (48 characters) and sub display (12 characters) on each instrument face.

Maximum slope distance
1,999,999 m (6,561.66 ft).

Minimum display: Fine measurement: 1 mm (0.01 ft)

Coarse measurement: 10 mm (0.1 ft)

Tracking measurement: 10 mm
(0.1 ft)

Measuring time:

	Mode		
	Fine measurement	Coarse measurement	Tracking measurement
Slope distance	5.5 s + every 3.5 s	2.5 s + every 1 s	2.5 s + every 0.4 s
Horizontal distance			
Height difference			
Coordinates	6 s + every 3.5 s	3 s + every 1 s	3 s + every 0.9 s
Remote elevation	1 s + every 0.6 s		
Horizontal distance between two points	6.5 s + every 3.5 s	3.5 s + every 1 s	3.5 s + every 0.9 s

(When tilt correction is not being applied, all measuring times are 0.2 sec less.)

Atmospheric correction:	Input temperature and pressure for automatic ppm calculation to nearest 1 ppm.
Input temperature range:	-30°C to +60°C (°C/°F selectable)
Input pressure range:	500 mb to 1,400 mb (mb/mmHg/inchHg selectable)
Prism constant correction:	-99 mm to +99 mm (in 1 mm steps)
Earth-curvature and refraction correction:	Selectable ON/OFF
Audio target acquisition:	Selectable ON/OFF
Signal source:	Infrared LED
Light intensity control:	Automatic

Angle measurement

Telescope

Length:	170 mm (6.7 inches)
Aperture:	45 mm (1.8 inches)
Magnification:	30x
Resolving power:	3"
Image:	Erect
Field of view:	1°30' (26 m/1,000 m)
Minimum focus:	1.3 m (4.3 ft)
Reticle illumination:	Bright or dim settings

Horizontal and Vertical circles

Type:	Incremental with 0 index
Minimum display:	5" (1 mgon)

Accuracy

	Standard deviation of mean of measurement taken in positions I and II (DIN 18723)
H:	5" (1.5 mgon)
V:	5" (1.5 mgon)

Automatic compensator

Type:	Selectable ON/OFF
Type:	Liquid, 2-axis tilt sensor
Minimum display:	5" (1 mgon)
Range of compensation:	±3'

Display

Range:	-1,999°59'55" to 1,999°59'55" (-1,999.999 gon to 1,999.999 gon)
--------	--

Measuring mode	
Horizontal angle:	Right/Left/Repetition of angles
Vertical angle:	Zenith 0° (0 gon) or Horizontal 0° (0 gon) or Horizontal 0°±90° (0 gon±100 gon)
Measuring time:	Less than 0.5 s
Sensitivity of levels	
Plate level:	30"/2 mm
Circular level:	10"/2 mm
Optical plummet	
Image:	Erect
Magnification:	3x
Minimum focus:	0.1 m (0.3 ft)
Data input/output:	Asynchronous serial, RS-232C compatible
Self-diagnostic function:	Provided
Power saving cut off:	30 minutes after operation
Operating temperature:	-20°C to +50°C (-4°F to +122°F)
Power source:	Ni-Cd battery, BDC18 (6V)
Working duration:	About 600 measurement at 25°C (77°F), distance and angle measurement; 9 hours at 25°C, angle measurement only. (About 4,000 measurements, distance and angle measurement; 70 hours at 25°C, angle measurement only, with optional battery BDC12.)
Charging time:	12 to 15 hours; standard charger CDC11/CDC11D (depending on input voltages) (1 hour, optional charger CDC12A, CDC13, CDC15.)
Instrument height:	236 mm
Size:	168 (W) x 170 (D) x 371 (H) mm (Without handle: H: 330 mm)
Weight:	7.3 kg (w/internal battery)

26. MAINTENANCE

- 1) Wipe off moisture completely if the instrument gets wet during survey work.
- 2) Always clean the instrument before returning it to the case.

The lens requires special care. Dust it off with the lens brush first, to remove minute particles. Then, after providing a little condensation by breathing on the lens, wipe it with a soft clean cloth or lens tissue.

- 3) Store the SET4B in a dry room where the temperature remains fairly constant.
- 4) If the battery is discharged excessively, its life may be shortened. Store it in a charged state.
- 5) Check the tripod for loose fit and loose screws.

The specifications and general appearance of the instrument may be altered at any time and may differ from those appearing in catalogues and this operator's manual.

THE LIETZ COMPANY

9111 Barton, P.O. Box 2934, Overland Park, Kansas 66201, U.S.A.
Phone 913-492-4900 Fax. 913-492-0188

SOKKISHA CANADA INC.

820 Denison Street, Unit 1, Markham, Ontario, Canada L3R 3K5
Phone 416-475-1450 Fax. 416-475-1453

SOKKISHA PTY. LTD.

107 Leicester Street, Carlton, Victoria 3053, Australia
Phone 03-347-5844 Fax. 03-347-0740

SOKKISHA NEW ZEALAND

20 Constellation Drive, Mairangi Bay, Auckland 10, C.P.O. Box 4464,
Auckland, New Zealand
Phone 09-479-3064 Fax. 09-479-3066

SOKKISHA EUROPE B.V.

Damsluisweg 1, 1332 EA Almere, P.O. Box 1292, 1300 BG Almere,
The Netherlands
Phone 03240-22880 Fax. 03240-26241

SOKKISHA U.K. LTD.

Unit 5, Oak Court, Betts Way, Crawley, West Sussex, RH10 2GB,
United Kingdom
Phone 0293-561618 Fax. 0293-561626

SOKKISHA DEUTSCHLAND GmbH

Emil-Hoffmann-Str. 7a, 5000 Köln 50, Germany
Phone 2236-64058 Fax. 2236-62675

SOKKISHA FRANCE S.A.

12 Avenue, Gabriel Peri 78360, Montesson, France
Phone 1-30-53-09-73 Fax. 1-39-76-63-15

SOKKISHA ITALIA S.R.L.

Via Bologna 50, 10152 Torino, Italy
Phone 011-248-0080 Fax. 011-248-2702

SOKKISHA SWEDEN AB

Transportgatan 5, S-422 46 Hisings Backa, Sweden
Phone 031-581550 Fax. 031-528580

SOKKISHA BELGIUM N.V.

Geheer Businesspark, Ockenveeld 1-1A, B1730 Aarschot, Belgium
Phone 02-466-62-30 Fax. 02-466-93-00

SOKKISHA KOREA CO., LTD.

Rm. 401, Kwan Seo Bldg, 561-20 Sinse-Dong, Kangnam-ku, Seoul,
Republic of Korea
Phone 02-514-0491 Fax. 02-514-0495

SOKKISHA SINGAPORE PTE LTD.

8001 Beach Road, #21-06, Golden Mile Tower, Singapore 0719
Phone 292-5483 Fax. 293-7916

SOKKISHA CO.,LTD.

1-1, TOMIGAYA 1-CHOME,
SHIBUYA-KU, TOKYO 151, JAPAN
PHONE 03-465-5211 FAX.03-465-5203
CABLE "SOKKISHA" TOKYO
TELEX SURSOK J28518