

SURVEYING INSTRUMENTS

SOKKIA

SET5/SET5S

Electronic Total Station



OPERATOR'S MANUAL

Congratulations on your purchase of the SET5!
Before using the instrument, please read this operator's
manual.

CONTENTS,

QUICK GUIDE

FEATURES

1. NAMES OF PARTS	1
2. PRECAUTIONS	2
3. KEY FUNCTIONS	4
4. MODE DIAGRAM	5
5. DISPLAY SYMBOLS	6
6. BATTERY BDC25: MOUNTING	7
7. SETTING UP THE INSTRUMENT	8
7.1 Centring	8
7.2 Levelling	9
7.3 Focussing	11
8. PREPARATION FOR POWER ON	12
9. POWER ON AND INSTRUMENT CHECKS	13
[Note: Power-saving cut-off]	14
10. PREPARATION FOR MEASUREMENT	15
10.1 Indexing the vertical and horizontal circles	15
[Note: Horizontal angle back-up]	16
[Note: Automatic vertical angle compensation]	16
10.2 Target sighting	17
[Note: Parallax]	17
10.3 Display and reticle illumination	18
11. ANGLE MEASUREMENT	19
11.1 Measure the horizontal angle between two points – Zero set –	19
11.2 Set the horizontal circle to a required value – Angle hold –	20
11.3 Select the horizontal display – Angle right/left/repetition –	21
[Note: Horizontal angle repetition mode]	21
12. DISTANCE MEASUREMENT	23
12.1 Atmospheric correction	23
12.2 Prism sighting and return signal check	25
12.3 Distance and angle measurement	27

13. ERROR CODES	30
14. CHECKS AND ADJUSTMENTS	31
14.1 Plate level	31
14.2 Circular level	33
14.3 Tilt sensor	34
14.4 Reticle	36
14.5 Optical plummet	38
14.6 Additive distance constant	39
14.7 Distance measurement check flow chart	40
15. INSTRUMENT PARAMETERS	41
No. 1 Prism constant correction	42
No. 2 Distance mode	42
No. 3 Distance units	43
No. 4 Earth curvature and refraction correction	43
No. 5 Audio for return signal	43
No. 6 Vertical angle mode	44
No. 7 Vertical circle indexing	45
No. 8 Vertical angle tilt compensation	45
No. 9 Horizontal circle indexing	45
No. 10 Angle units	46
No. 11 Auto power cut-off	46
No. 12 Illumination auto cut-off	47
No. 13 Reticle illumination brightness	47
16. POWER SYSTEM	48
17. REFLECTING PRISMS AND ACCESSORIES	50
18. STANDARD EQUIPMENT	52
19. MAINTENANCE	53
APPENDIX 1: MANUALLY INDEXING THE VERTICAL CIRCLE	54
APPENDIX 2: ACCURACY OF MEASUREMENT OF ATMOSPHERIC CONDITIONS	55
APPENDIX 3: EARTH CURVATURE AND REFRACTION CORRECTION	56
APPENDIX 4: STANDARD ACCESSORIES	57
APPENDIX 5: OPTIONAL ACCESSORIES	58
SPECIFICATIONS	60
ATMOSPHERIC CORRECTION CHART	63

• The specifications and general appearance of the instrument may be altered at any time and may differ from those appearing in catalogues and this operator's manual.

QUICK GUIDE

- Ensure that the battery is charged before measurement.

1

Setting up the instrument

- Battery mounting ↗ P. 7
- Centring/Levelling/Focussing ↗ P. 8

2

Preparation for power on

↗ P. 12

- Prism constant correction/Distance mode/Distance units/Earth curvature and refraction/Vertical angle display/ Angle units

3

Power on/ H and V circle indexing

- Power on/Instrument self-check ↗ P. 13
- Vertical/Horizontal circle indexing ↗ P. 15
- Target sighting ↗ P. 17

4

Angle measurement

- Measure the angle between two points ↗ P. 19
- Set the horizontal circle to a required value ↗ P. 20

5

Distance measurement

- Atmospheric correction ↗ P. 23
- Return signal check ↗ P. 25
- Distance and angle measurement ↗ P. 27

Note: The instrument parameters are set to default settings at the factory. Before use, ensure that the parameters are set to your required options. See Section 2.

QUICK GUIDE

- Ensure that the battery is charged before measurement.

1

Setting up the instrument

- Battery mounting [P. 7](#)
- Centring/Levelling/Focussing [P. 8](#)

2

Preparation for power on [P. 12](#)

- Prism constant correction/Distance mode/Distance units/Earth curvature and refraction/Vertical angle display/ Angle units

3

Power on/ H and V circle indexing

- Power on/Instrument self-check [P. 13](#)
- Vertical/Horizontal circle indexing [P. 15](#)
- Target sighting [P. 17](#)

4

Angle measurement

- Measure the angle between two points [P. 19](#)
- Set the horizontal circle to a required value [P. 20](#)

5

Distance measurement

- Atmospheric correction [P. 23](#)
- Return signal check [P. 25](#)
- Distance and angle measurement [P. 27](#)

Note: The instrument parameters are set to default settings at the factory. Before use, ensure that the parameters are set to your required options. See Section 2.

FEATURES

< Light in weight, highly accurate total station >

- The total weight of the instrument is 6.4 kg including the handle and battery. For total station operations, all keys on the keyboard can be used for two or more functions.

< 0 index on vertical and horizontal circles >

- Both the horizontal and the vertical circles are provided with 0 index points. The horizontal index value is stored in the short-term (15-hour) memory, so that even after power is lost (i.e. battery change or automatic power cut-off), the previous index position can be recovered when the instrument is switched on and the circle is indexed again.

< Automatic tilt compensation of vertical angles >

- The tilt angle of the vertical axis is measured by an internal sensor. The vertical angle value can be automatically compensated for this tilt angle and the compensated value displayed.

< Instrument parameter settings stored in memory >

- The SET5 has an internal memory which stores the instrument parameter settings. The parameter settings can be changed by key operation and the new settings are memorized even after power off.

< Rechargeable battery >

- The SET5 is powered by a rechargeable battery. For continuous angle measurement, a fully-charged battery supplies power for 17 hours, and for continuous angle and distance measurement, the battery will allow operation for 2.5 hours (at an ambient temperature of 25°C).

< Data output function >

- An RS-232C data output connector is provided for use with a data collector or external computer. The SET5 can transmit slope distance and horizontal and vertical angle data to an external device.

1. NAMES OF PARTS

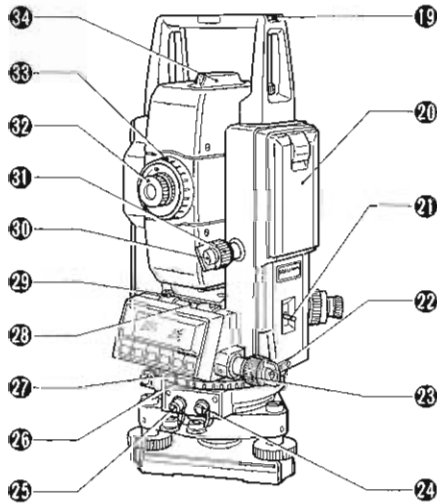
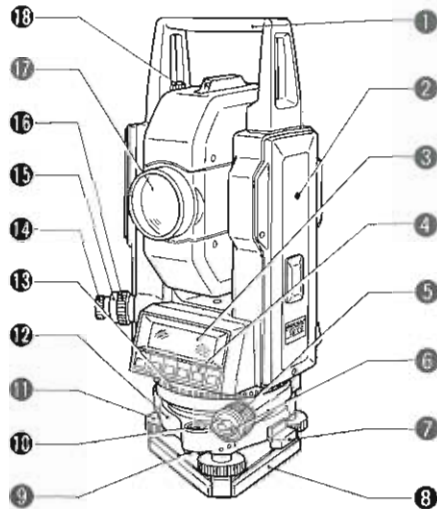

- ① Handle
- ② Instrument height mark
- ③ Display
- ④ Keyboard
- ⑤ Lower clamp cover
- ⑥ Lower clamp
- ⑦ Tribrach clamp
- ⑧ Base plate
- ⑨ Circular level adjusting screw
- ⑩ Circular level
- ⑪ Levelling foot screw
- ⑫ Tribrach
- ⑬ Horizontal circle positioning ring
- ⑭ Optical plummet eyepiece
- ⑮ Optical plummet reticle adjusting cover
- ⑯ Optical plummet focussing ring
- ⑰ Objective lens
- ⑱ Handle securing screw
- ⑲ Tubular compass slot
- ⑳ Battery BDC25
- ㉑ Power switch
- ㉒ Horizontal clamp
- ㉓ Horizontal fine motion screw
- ㉔ Data output connector
- ㉕ External power source connector
- ㉖ 0 mark
- ㉗ 0 index mark
- ㉘ Plate level
- ㉙ Plate level adjusting screw
- ㉚ Vertical clamp
- ㉛ Vertical fine motion screw
- ㉜ Telescope eyepiece
- ㉝ Telescope focussing ring
- ㉞ Peep sight

FEATURES

〈Light in weight, highly accurate total station〉

- The total weight of the instrument is 6.4 kg including the handle and battery. For total station operations, all keys on the keyboard can be used for two or more functions.

〈0 index on vertical and horizontal circles〉

- Both the horizontal and the vertical circles are provided with 0 index points. The horizontal index value is stored in the short-term (15-hour) memory, so that even after power is lost (i.e. battery change or automatic power cut-off), the previous index position can be recovered when the instrument is switched on and the circle is indexed again.

〈Automatic tilt compensation of vertical angles〉

- The tilt angle of the vertical axis is measured by an internal sensor. The vertical angle value can be automatically compensated for this tilt angle and the compensated value displayed.

〈Instrument parameter settings stored in memory〉

- The SET5 has an internal memory which stores the instrument parameter settings. The parameter settings can be changed by key operation and the new settings are memorized even after power off.

〈Rechargeable battery〉

- The SET5 is powered by a rechargeable battery. For continuous angle measurement, a fully-charged battery supplies power for 17 hours, and for continuous angle and distance measurement, the battery will allow operation for 2.5 hours (at an ambient temperature of 25°C).

〈Data output function〉

- An RS-232C data output connector is provided for use with a data collector or external computer. The SET5 can transmit slope distance and horizontal and vertical angle data to an external device.

2. PRECAUTIONS

- 1) When the SET5 is not used for a long time, check it at least once every three months.
- 2) Handle the SET5 with care. Avoid heavy shocks or vibration.
- 3) When removing the SET5 from the carrying case, never pull it out by force. The empty carrying case should then be closed to exclude dust.
- 4) If any problems are found with the rotatable portion, screws or optical parts (e.g. lens), contact our agent.
- 5) Never place the SET5 directly on the ground.
- 6) Never carry SET5 on the tripod to another site.
- 7) Protect the SET5 with an umbrella against strong sunlight and rain.
- 8) When the operator leaves the SET5, the vinyl cover should be placed over the instrument.
- 9) Do not aim the telescope at the sun.
- 10) Always remove the battery from the SET5 before returning it to the case.
- 11) Always switch the power off before removing the internal battery.
- 12) Do not wipe the display ③, keyboard ④ or the carrying case with any organic solvent.
- 13) When the SET5 is placed in the case, follow the layout plan.
- 14) Make sure that the SET5 and the protective lining of the carrying case are dry before closing the case. (The case is hermetically sealed; if moisture is trapped inside, damage to the instrument could occur.)

IMPORTANT:

When the SET5 leaves our factory, the tribrach clamp is locked with a screw. Loosen it and leave it loose.

Tribrach clamp locking screw



3. KEY FUNCTIONS

- The upper functions are accessed by pressing **SHFT** and the required key.

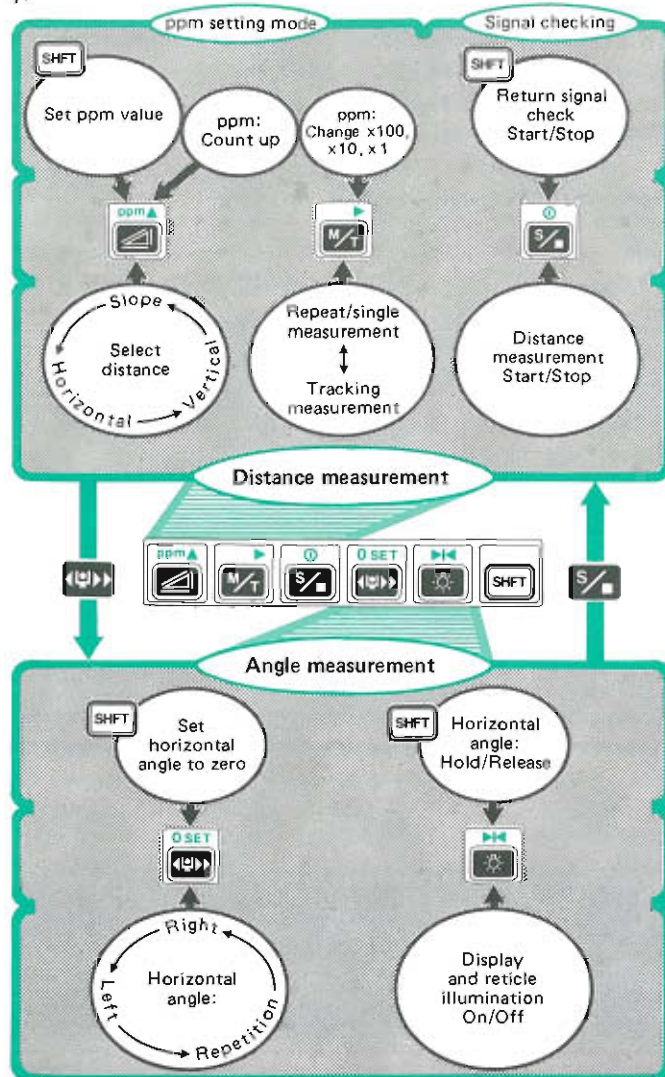

4. MODE DIAGRAM

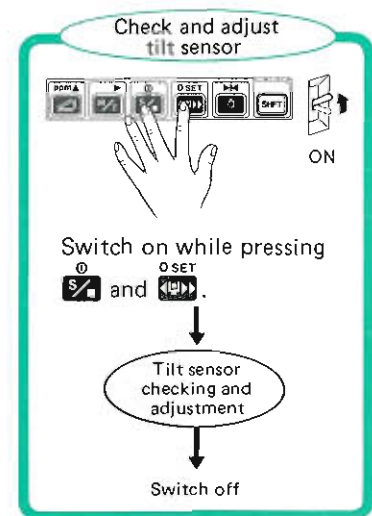
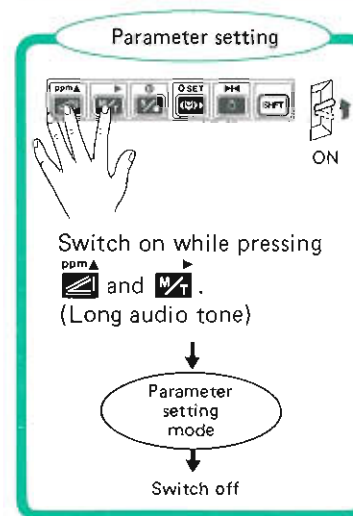
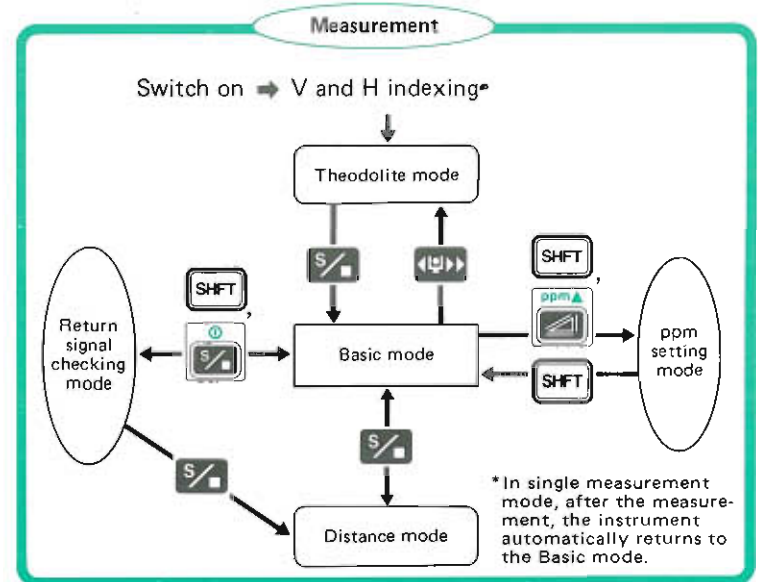

5. DISPLAY SYMBOLS

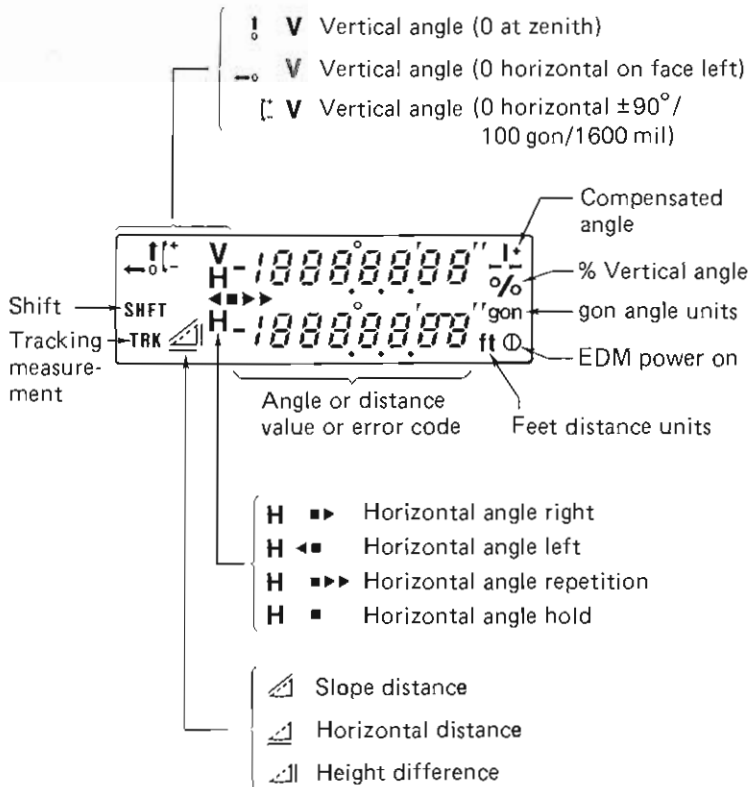

6. BATTERY BDC25: MOUNTING

- Charge the battery before measurement.

P. 48

* Ensure that the power switch **2** is OFF.

< Mounting the battery >

- 1) Close the battery release button cover.
- 2) Match the battery guide with the hole in the instrument battery recess.
- 3) Press the top of the battery until a click is heard.

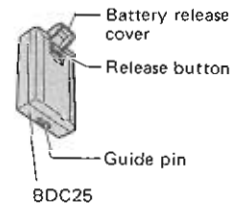

< Removing the battery >

- 1) Open the battery release cover.
- 2) Press the release button downward.
- 3) Remove the battery.

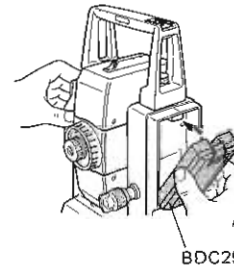

7. SETTING UP THE INSTRUMENT

- Mount the battery in the instrument before performing this operation.

7.1 Centring

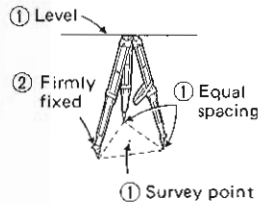

- 1) Ensure that:
 - 1 The tripod head is approximately level, and over the surveying point.
 - 2 The tripod shoes are firmly fixed in the ground.

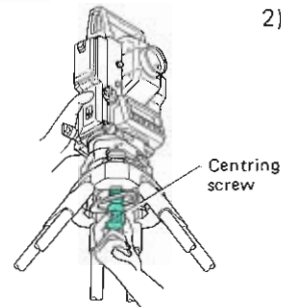

- 2) Place the SET5 on the tripod head. Support it with one hand and insert and tighten the centring screw with the other.

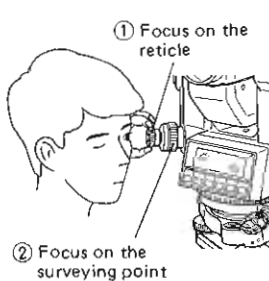

- 3) Focus on the surveying point:
 - 1 Turn the optical plummet eyepiece 14 to focus on the reticle.
 - 2 Turn the optical plummet focussing ring 16 to focus on the surveying point.

7.2 Levelling

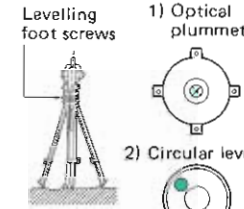

- 1) Adjust the levelling foot screws 11 to centre the surveying point in the optical plummet reticle.

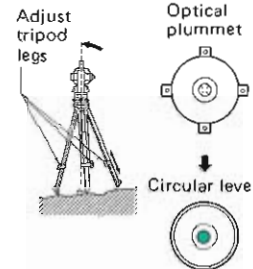

- 2) Observe the off-centre direction of the circular level 10 bubble.
- 3) Shorten the tripod leg nearest the bubble direction or extend the leg farthest from this direction. Generally, two tripod legs must be adjusted to centre the bubble.

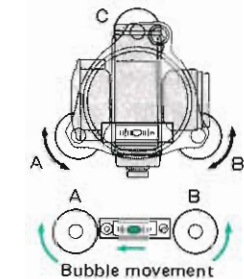

- 4) Using the horizontal clamp 22, turn the upper part of the instrument until the plate level 24 is parallel to a line between levelling screws A and B.

- 5) Centre the plate bubble using levelling screws A and B.

Note: The bubble moves towards a clockwise-rotated foot screw.

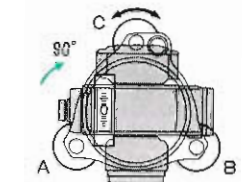

- 6) Turn the upper part through 90°. The plate level is now perpendicular to a line between levelling screws A and B. Centre the plate level bubble using levelling screw C.

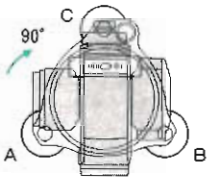

7) Turn the upper part a further 90° and check the bubble position.

If the bubble is off-centre, either perform the plate level adjustment described on page 31 or carefully adjust levelling screws A and B in equal and opposite directions to remove half of the bubble displacement. Again turn the upper part a further 90° and use levelling screw C to remove half of the displacement in this direction.

- The bubble should now remain in the same position for any position of the upper part. (If it does not, repeat the levelling procedure.)

The following steps are different for the SET5 and SET5S.

(SET5)

8) Look through the optical plummet eyepiece. Loosen the centring screw slightly, then carefully slide the instrument over the tripod head until the surveying point is exactly centred in the reticle. Re-tighten the centring screw.

9) Repeat procedures 4)–8) until the instrument is correctly levelled and centred over the surveying point.

(SET5S)

8) Turn the tribrach shifting clamp anticlockwise. Adjust the instrument position on the tribrach to centre the surveying point. Tighten the shifting clamp to fix the instrument in the centre position.

Note: The SET5S shifting tribrach can be adjusted up to $\pm 8\text{mm}$.

7.3 Focussing

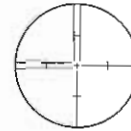

- 1) Look through the telescope at a bright, featureless background.
- 2) Turn the eyepiece  clockwise, then anticlockwise until just before the reticle image goes out of focus. Using this procedure, frequent reticle re-focussing is not necessary, since **your** eye is focussed at infinity.

8. PREPARATION FOR POWER ON

The SET5 instrument parameters are set at the factory to the options tabulated below. Before using the instrument for the first time, check that these parameters are set to your required options.

- To change the parameter options, see "INSTRUMENT PARAMETERS" on page 41.

Parameter No.	Function	Options
1	Prism constant correction	<u>-30mm</u> (adjustable from 0 to -90mm in 10mm steps.)
2	Distance mode	<u>Repeat/Single</u> measurements <i>☞</i> P. 42
3	Distance units	<u>Metres</u> or feet
4	Earth curvature and refraction correction	<u>Not applied</u> or applied <i>☞</i> P. 56
6	Vertical angle	<u>Zenith 0</u> /Horizontal 0/ Horizontal 0±90° (100 gon/1600 mil)/ % vertical angle
10	Angle units	<u>Degrees</u> or gon or mil

(Underlined values are the factory settings.)

- See page 41 for a complete list of the instrument parameters.

9. POWER ON AND INSTRUMENT CHECKS

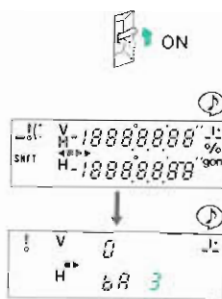

- Turn the SET5 power switch **ON**. The audio tone sounds and all the display symbols are shown on the display while the instrument performs self-diagnostic checks.
- On successful completion of the checks, the battery power is displayed as a numeric code for three seconds.

	(Angle only)	(At 25°C) (Distance and angle)
0	Less than 1 hr	Less than 10 min
1	1 to 11 hrs	10 min to 1 hr 20 min
2	11 to 16 hrs	1 hr 20 min to 2.5 hrs
3	16 to 17 hrs	2.5 hrs to 2 hrs 40 min

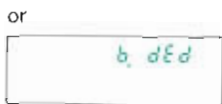

If **b. dEd** is displayed, the battery voltage is too low for measurement. Turn the power switch off and re-charge the battery. (This display also occurs during measurement when the battery power is low.)

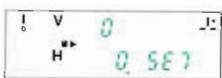

- The "V 0/H 0 SE7" display indicates that the instrument is ready for horizontal and vertical circle indexing. When the previous 0 position on the horizontal circle is memorized, SE7. is displayed. Refer to "Horizontal angle back-up" on page 16.



E 114, **E 115**, **E 116** or **E 117** is displayed when the tilt angle exceeds 3'. Re-level the SET5 using the plate level bubble.

[Note: Power-saving cut-off]

- If the power switch is left on, the SET5 has the option to switch off automatically 30 minutes after the last key operation.

Instrument parameter No. 11 P. 41

- Parameter 11 can be used to switch off and on the 30-minute power cut-off facility.

10. PREPARATION FOR MEASUREMENT

10.1 Indexing the vertical and horizontal circles

(When H and V circle indexing parameters are set to "R".)

Turn the SET5 power switch **Ⓚ** ON.

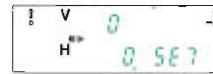

..... Waiting for vertical circle indexing

..... Waiting for horizontal circle indexing

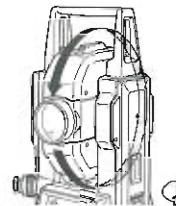

<Vertical circle indexing>

- 1) Loosen the vertical clamp **Ⓚ**, and transit the telescope completely.
(Indexing occurs when the objective lens crosses the horizontal plane in face left.)
The audio tone sounds and the vertical angle (V) is displayed.

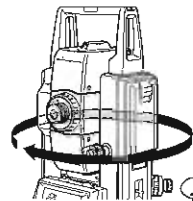
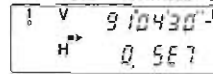

<Horizontal circle indexing>

- 2) Loosen the horizontal clamp **Ⓚ**, and rotate the upper part completely.
(Indexing occurs when the 0 index mark **Ⓚ** passes the 0 mark **Ⓚ** on the horizontal positioning ring.)
The audio tone sounds and the horizontal angle (H) is displayed.

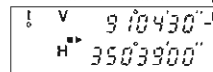

- Angle measurement can now begin.
(The instrument is now in the theodolite mode.)

Note: Each time the instrument is switched on, the vertical and horizontal indexes must be redetermined.

Instrument parameter No. 7 P. 41

- Parameter 7 can be used to change the vertical circle indexing.
Options are indexing by transitting the telescope or indexing by face left, face right sightings. P. 54

[Note: Horizontal angle back-up]

- When parameter 9 is in the factory setting, the previous horizontal 0 position at power off is memorized for about 15 hours.

The horizontal left or right angle display selection is also memorized.

When the SET5 is switched ON and the horizontal circle is indexed again, the previous horizontal angle is recovered.

This function is useful when the battery voltage becomes low during measurement or after automatic power-off has taken place.

Instrument parameter No. 9 P. 41

- Parameter 9 can be used to change the horizontal circle indexing. Options are indexing by rotating the upper part or automatic indexing and zero setting at power on.

[Note: Automatic vertical angle compensation]

Automatic vertical angle compensation mark



- When the compensation mark is shown on the display, the vertical angle is automatically compensated for small tilt errors.
- Read the compensated vertical angle after the displayed angle value becomes steady.

Instrument parameter No. 8 P. 41

- Parameter 8 can be used to switch off and on the automatic vertical angle compensation; for example, the automatic compensation should be switched off if the display is unsteady due to vibration or strong wind.

10.2 Target sighting

Line the target with the white arrow in the peep sight.

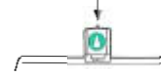

- Loosen the vertical and horizontal clamps ⑩, ⑫ and use the peep sight ⑬ to bring the target into the field of view.
- Re-tighten both clamps.
- Turn the focussing ring ⑭ to focus on the target.
- Use the vertical and horizontal fine motion screws ⑮, ⑯ to sight the target precisely. The last adjustment of each fine motion screw should be in a clockwise direction.

Position of the target in relation to the reticle:

- Angle only measurement:
Use the reflecting prism or the target.

- Distance and angle measurement:
Use the reflecting prism.

Note: Observe to the same point of the reticle when the telescope face is changed.

- Check that there is no parallax between the target image and the reticle.

[Note: Parallax]

- This is the relative displacement of the target image with respect to the reticle when the observer's head is moved slightly before the eyepiece.

Parallax will introduce reading errors and must be removed before observations are taken. Parallax can be removed by re-focussing.

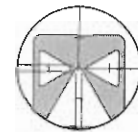

(Target centre)

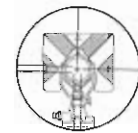

(Prism centre)

10.3 Display and reticle illumination



- Press to illuminate the display and reticle of the SET5.
- Press again to switch the illumination off.



Instrument parameter No. 12 P. 41

- Parameter 12 can be used to switch on/off the 30-second illumination automatic cut-off facility.

Instrument parameter No. 13 P. 41

- Parameter 13 can be used to select the illumination brightness (2 steps).

11. ANGLE MEASUREMENT

Check! before angle measurement:

1. The SET5 is set up correctly over the surveying point. P. 8
2. The remaining battery power is adequate. P. 13
3. The vertical angle display mode and angle units are correct. P. 12
4. The vertical and horizontal circles have been indexed. P. 15

11.1 Measure the horizontal angle between two points — Zero set —

Note: Horizontal angle 0 set



- Press , to set the horizontal angle to zero.

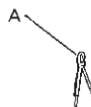

1) Sight the first target A.



2) Press , to set the horizontal angle display to zero.



3) Use the horizontal clamp and fine motion screw to sight target B.

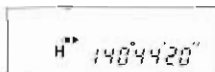

The displayed horizontal angle is the angle between points A and B.

11.2 Set the horizontal circle to a required value — Angle hold —

Note: Horizontal angle hold



- Press **SHFT**, to hold the displayed horizontal angle.

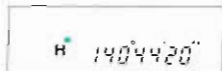

- The hold symbol is displayed.

- To release the horizontal angle hold, again press **SHFT**, .

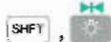

e.g. Set $60^{\circ}00'20''$ to reference target R.



- 1) Use the horizontal clamp and fine motion screw to turn the theodolite until an angle of $60^{\circ}00'20''$ is shown on the display.



- 2) Press **SHFT**, to hold the horizontal display, as above.

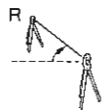

- 3) Use the horizontal clamp and fine motion screw to turn the theodolite to sight on the reference target R.



- 4) Press **SHFT**, to release the display hold. Reference target R has now been set to $60^{\circ}00'20''$.

11.3 Select the horizontal display — Angle right/left/repetition —

Note: Horizontal angle right/left/repetition



- Select the required horizontal angle display using the key.



(Display symbol : horizontal angle right)

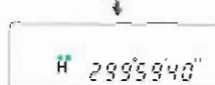

(Display symbol : horizontal angle left)

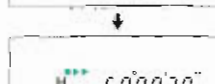

(Display symbol : horizontal angle by repetition)

[Note: Horizontal angle repetition mode]

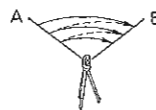

- For higher accuracy reading, the angle can be measured a number of times (up to an angle total of $\pm 1999^{\circ}59'50''$), and the average calculated.



- 1) Press until horizontal angle by repetition is selected. is displayed.

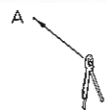

- 2) Sight target A.

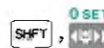

- 3) Press **SHFT**, to set the horizontal angle to zero.

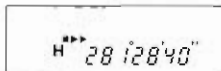
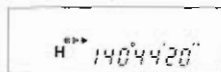

Double angle

- 4) Use the horizontal clamp (22) and fine motion screw (23) to sight on target B.

The angle between A and B is displayed.

- 5) Press **SHFT**, to hold the horizontal angle.

Use the LOWER clamp (6) and horizontal fine motion screw (23) to sight back on target A.

Press **SHFT**, to release the horizontal angle display hold.

- 6) Use the horizontal clamp (22) and fine motion screw (23) to sight target B again.

The double angle is displayed.

- 7) Repeat 5)–6) to measure the angle the required number of times, then divide the total angle value by the number of times it was measured to find the average angle value.

e.g. $281^{\circ}28'40'' / 2 = 140^{\circ}44'20''$

- To exit from the angle repetition routine, press .

12. DISTANCE MEASUREMENT

12.1 Atmospheric correction

- The atmospheric correction is necessary for accurate distance measurement, because the velocity of light in air is affected by the temperature and atmospheric pressure.

The SET5 is designed so that the correction factor is 0 for a temperature of +15°C (+59°F) and an atmospheric pressure of 1013 mb (29.9 inchHg).

Note: To obtain the average refractive index of the air throughout the measured light path, you should use the average atmospheric pressure and temperature. Take care when calculating the correction factor in mountainous terrain. P. 55

- Measure the temperature and pressure with a thermometer and a barometer and read the correction factor from the table on page 63.

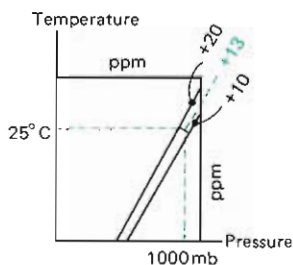

e.g. Temperature: +25°C
 Atmospheric pressure: 1000 mb
 Read correction value from the table.
 The correction value is +13 ppm.

The correction value can be calculated from:

$$X = 278.96 - \frac{0.2904 \times P \text{ (mb)}}{1 + 0.003661 \times t \text{ (}^{\circ}\text{C)}}$$

where: P = Atmospheric pressure in mb
 t = Temperature in Centigrade

To convert inchHg to millibars, divide by 0.0295.

To convert temperature from Fahrenheit to Centigrade, use the formula:

$$^{\circ}\text{C} = \frac{5 \text{ (}^{\circ}\text{F} - 32)}{9}$$

- The atmospheric correction value can be input to the SET5 as a value between -499 ppm and +499 ppm in 1 ppm steps.
- The input atmospheric correction value is stored in the memory for about 15 hours after the power is switched off.
- If the atmospheric correction is not required, set the ppm value to zero.

Note: ppm setting mode

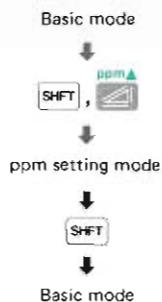

- Press **SHIFT**, **ppm** to go to the ppm setting mode from the Basic mode.

- **ppm** Count up

- **M/T** Change between the ×100 (-), ×10 and ×1 ppm columns.

- **SHIFT** Stores the value and exits to the Basic mode.

e.g. Set a ppm value of 13 ppm
From Basic mode:

Press **SHIFT**, **ppm** to go to the ppm setting mode.

The ×100 (-) ppm column flashes.

Set this column to 0 using **ppm**.
(-0, 0, 1, 2, 3, 4, -4, -3, -2, -1)

Press **M/T** to change to the ×10 ppm column. (Value flashes)

Set 1 to this column using **ppm**.

Press **M/T** to change to the ×1 ppm column. (Value flashes)

Set 3 to this column using **ppm**.

Press **SHIFT** to return to the Basic mode.

- The entered ppm value is stored in the memory for about 15 hours after the power is switched off.

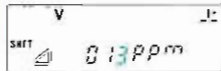
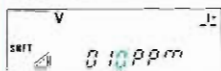
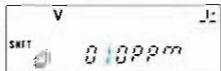

12.2 Prism sighting and return signal check

- Especially for long distances, it is useful to check that the return signal is adequate for measurement.

Note: Return signal checking mode

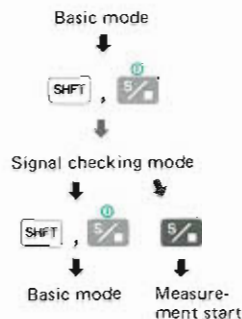

- Sight the centre of the reflecting prism with the telescope. *P. 17*

- Press **SHIFT**, **5/4** to go to the return signal checking mode.

Check the signal strength,

- Press **SHIFT**, **5/4** to return to the Basic mode, or press **5/4** to start measurement.

- The return signal level is displayed according to its strength. An optional audio tone is output when the signal strength is adequate.



No return signal. Sight the prism centre again. *P. 17*



Adequate for measurement.
(Optional audio tone is output.)







Return signal is too strong. If this display persists, please contact our agent.

Return signal audio tone on/off  P. 41

- Parameter 5 can be used to switch on/off the return signal audio tone.

12.3 Distance and angle measurement

Check! before distance and angle measurement:

1. The SET5 is set up correctly over the surveying point.  P. 8
2. The remaining battery power is adequate.  P. 13
3. The prism constant, the distance mode, the distance units and the curvature and refraction correction have been correctly set.  P. 12
4. The vertical angle format and angle units have been correctly set.  P. 12
5. The vertical and horizontal circles have been indexed.  P. 15
6. The SET5 is in the Basic mode.
7. The atmospheric correction is correctly set.  P. 23
8. The centre of the reflecting prism is being sighted and the return signal is adequate for measurement.  P. 25





- For simultaneous measurement of distance and horizontal angle, the horizontal angle can be set to zero or a required value. For horizontal angle operations, see page 19—.

M/T

- 1) In Basic mode, select repeat/single* or tracking measurement. (Tracking measurement = Distance value displayed at first after 1.5 sec, then every 0.4 sec in cm units.)

The **TRK** symbol is shown on the display in tracking mode.

- * Repeat or single measurement can be selected by instrument parameter No. 2.  P. 42

-  : Slope distance
-  : Horizontal distance
-  : Height difference
-  : Measurement start

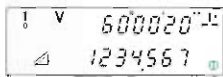

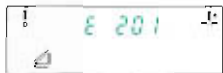

 : Measurement stop



 : Measurement stop

2) Select the distance measuring mode by pressing .

3) Press  to start the measurement. The display flashes to show that the measurement is being performed.



4) The selected distance and angle will be displayed after measurement. In repeat or tracking measurement mode, press  to stop the measurement.

- In single measurement mode, the stop key does not need to be pressed.

Note: If **E 201** is displayed, the return signal is absent. In this situation, press  to stop the measurement, sight the prism correctly and re-measure. If any other error code is displayed, see page 30.

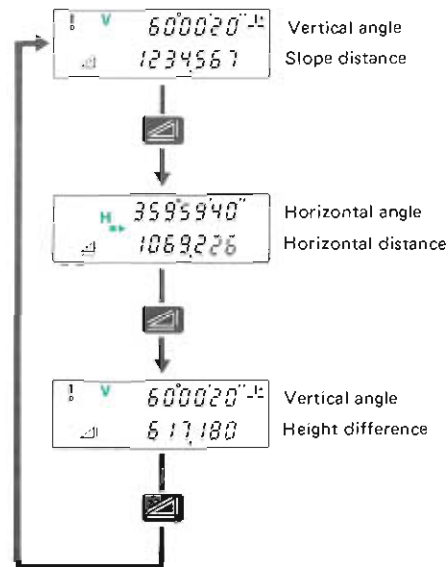
- After the measurement has been stopped, the slope distance, horizontal distance and vertical and horizontal angle data are stored in the memory.



- The vertical angle and slope distance, the horizontal angle and horizontal distance, or the vertical angle and height difference can be displayed by pressing .
- Press  to go to the Theodolite mode from the Basic mode.

13. ERROR CODES

- If there is any fault in the SET5 operation, the error codes shown below will be displayed.

Display	Meaning	Action
b. dEd	Battery voltage is too low.	Replace the battery with a charged one, or charge the battery.
E 100	* Error when measuring a horizontal angle.	Index the horizontal circle again.
E 101	* Error when measuring a vertical angle.	Index the vertical circle again.
E 114	Tilt angle of trunnion direction exceeds $-3'$.	Re-level the SET5.
E 115	Tilt angle of sighting direction exceeds $-3'$.	
E 116	Tilt angle of trunnion direction exceeds $+3'$.	
E 117	Tilt angle of sighting direction exceeds $+3'$.	
E 000 E 001	Incoming reflection was disturbed.	
E 005	Measurement conditions are bad.	
S. OFF E 201	Incoming reflection was totally absent at start of measurement.	

*If the SET5 telescope or upper part is rotated faster than four revolutions per second, the error indication "E 100" or "E 101" is displayed.

- When an error indication persists, or if an error indication "E xxx" is displayed with any number other than those displayed above, please contact our agent.

14. CHECKS AND ADJUSTMENTS

- It is important that the SET5 is periodically checked and adjusted. In addition, the instrument should be checked after transportation, long storage or when damage to the instrument is suspected to have occurred.

14.1 Plate level

- The glass tube of the plate level is sensitive to temperature change or shock. Check and adjust as follows:

(Check)

- 1) Turn the upper part of the instrument until the plate level is parallel to a line between levelling foot screws A and B. Centre the plate level bubble using levelling screws A and B.

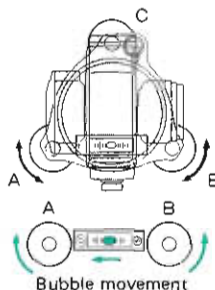

Note: The bubble moves towards a clockwise-rotated footscrew.

- 2) Loosen the horizontal clamp  and turn the upper part 90°. i.e. The plate level is perpendicular to a line between levelling screws A and B. Centre the plate level bubble using levelling screw C.

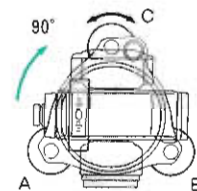

- 3) Turn the upper part through 180° and check the bubble position. If the bubble is still centred, no adjustment is necessary. If the bubble is not centred, adjust as follows:

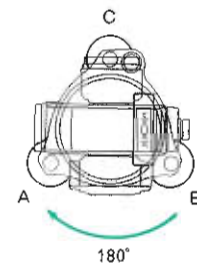

4) Use levelling screws



→ 1/2

5) Use adjusting pin



→ Centre

< Adjustment >

4) Correct half of the bubble displacement using levelling screw C.

5) Correct the remaining half displacement with the adjusting pin.

Note: The bubble moves away from a clockwise rotation of the adjusting screw.

6) Repeat the procedures from 1) until the bubble remains centred for any position of the upper part.

If the bubble is not still centred in the plate level, please contact your Sökkisha agent.

14.2 Circular level

< Check >

1) Perform the plate level adjustment as in 14.1, or carefully level the instrument using the plate level.

2) Check the position of the circular level bubble. If the bubble is off-centre, adjust as follows:

< Adjustment >

3) Note the off-centre direction of the bubble.

4) Loosen the adjusting screw farthest from this direction to centre the bubble.

5) Adjust all three adjusting screws until the tension of each screw tightening is the same, and the bubble is centred.

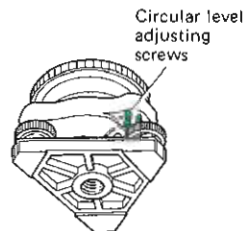

Warning: Over-tightening the adjusting screws may damage the circular level. Unequal tightening of the screws may mean that the bubble will go out of adjustment.

If the bubble is not still centred in the circular level, please contact your Sökkisha agent.

14.3 Tilt sensor

- If there is a tilt 0 point error, the tilt angle is not 0 when the instrument is properly levelled, and it causes an angle error. This tilt 0 point error can be checked and adjusted as follows.

<Check>

1) Carefully level the SET5.

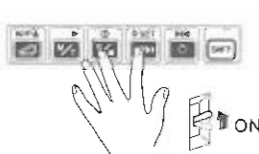

2) Press the and keys and switch the SET5 on at the same time.

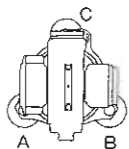

3) The tilt angle is displayed at the upper line, and the horizontal angle is displayed at the lower line.

Note the tilt angle value A, e.g. -20".



Tilt angle A
Horizontal angle

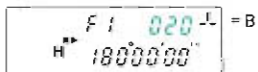
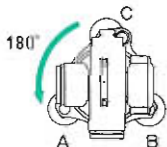

= B

$$(A + B)/2 \leq \pm 20''$$

4) Loosen the horizontal clamp and turn the upper part through $180^\circ \pm 5'$ watching the display of horizontal angle.

Note the tilt angle value B at the 180° position, e.g. 20".

Calculate the offset value: $(A + B)/2$

e.g. $(-20 + 20)/2 = 0$

- If the offset value is $\pm 20''$ or less, no adjustment is necessary, and switch the power off to finish the check.
- If the offset value is greater than $\pm 20''$, the sensor index should be adjusted as follows:

<Adjustment>

5) Press , , to input the tilt angle B at the 180° position.

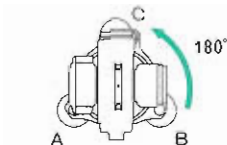

6) Loosen the horizontal clamp and turn the upper part back to the 0° horizontal angle position.

The tilt angle for this position is displayed.

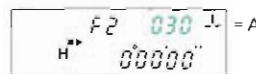

= A



7) Press , to input this displayed tilt angle A.

The audio tone sounds and the tilt 0 point data is displayed.

(If the tilt 0 point data is greater than 400 ± 120 , please contact your Sökkisha agent.)

After three seconds, the adjusted new tilt angle value is displayed.

Note this tilt angle value C, e.g. 5".

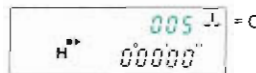

= C

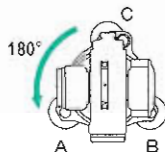

8) Loosen the horizontal clamp and turn the upper part to the 180° horizontal angle position.

Note the tilt angle value D, e.g. -5".

Calculate the new offset value: $(C + D)/2$

e.g. $(5 + (-5))/2 = 0$

Confirm that the offset value is $\pm 20''$ or less and switch the power off.

If the offset value is greater than $\pm 20''$, switch the power off and repeat the adjustment procedures from 1).

If the offset value is greater than $\pm 20''$ in spite of repeating the adjustment, please contact your Sökkisha agent.



= D

$$(C + D)/2 \leq \pm 20''$$



Switch off

14.4 Reticle

Note: Before this procedure, check the vertical index as in 14.3.

Perpendicularity of the reticle to the horizontal axis

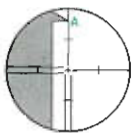

< Check >

- 1) Carefully level the SET5.

Select and sight a clear target on the upper part A of the reticle line.



- 2) Turn the telescope vertical fine motion screw until the target is on the lower part of the reticle B.

Check that the target is still positioned centrally within the reticle lines.

If the target is off-centre, please contact your Sökkisha agent.

Vertical and horizontal reticle line positions

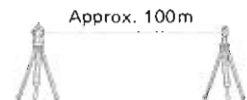

< Check >

- 1) Set up a clear target 100 m (330 ft) from the SET5. Carefully level the SET5, switch on and index the vertical and horizontal circles.

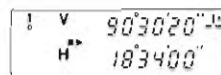

Face left

- 2) Sight the target on face left. Read the horizontal and vertical angles.
e.g. H: 18°34'00" a_l
V: 90°30'20" b_l

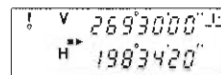

Face right

- 3) Now sight the target on face right and read the horizontal and vertical angles.
e.g. H: 198°34'20" a_r
V: 269°30'00" b_r

- 4) Subtract the horizontal face left angle from the horizontal face right angle. The difference should be $180^\circ \pm 40''$. Add the vertical face left and face right angles. The sum should be $360^\circ \pm 40''$.
 $a_r - a_l = 180^\circ 00' 20''$
 $b_r + b_l = 360^\circ 00' 20''$

- 5) If either of the values are greater than $\pm 40''$, repeat the above procedures. If, after repeating the procedures, the values are still greater than $\pm 40''$, please contact your Sökkisha agent.

14.5 Optical plummet

<Check>

- 1) Carefully level the SET5 and exactly centre a surveying point in the reticle of the optical plummet.
- 2) Turn the upper part 180° and check the position of the surveying point in the reticle. If the surveying point is still centred, no adjustment is necessary. If the surveying point is not still centred in the optical plummet, please contact your Sokkisha agent.



14.6 Additive distance constant

- The additive distance constant of the SET5 is adjusted to 0 before delivery. However, the additive constant can change with time and so should be determined periodically and then used to correct distances measured.

<Check>

- 1) Select points A and B on flat ground about 100 m (330 ft) apart, and C in the middle.

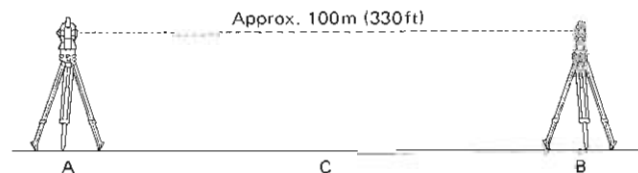

- 2) Set up the SET5 at A and measure the distance AB.

- 3) Move the SET5 to C, and measure the distances CA and CB.

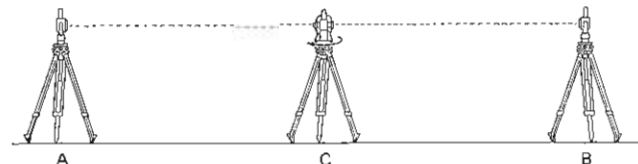

- 4) Compute the additive distance error K using the formula:

$$K = \overline{AB} - (\overline{CA} + \overline{CB})$$

\overline{AB} , \overline{CA} , \overline{CB} : Average of ten measurements.

- 5) Obtain the K value three times. If all K are greater than ± 5 mm, please contact your Sokkisha agent.

Note: Ensure that the prism height is the same as the height of the SET5 objective lens centre. If the ground is not level, use an automatic level to set the correct instrument heights of all points.

14.7 Distance measurement check flow chart

- Before this check, set the distance measuring mode to repeat measurement mode, then perform the procedures in the flow chart below.

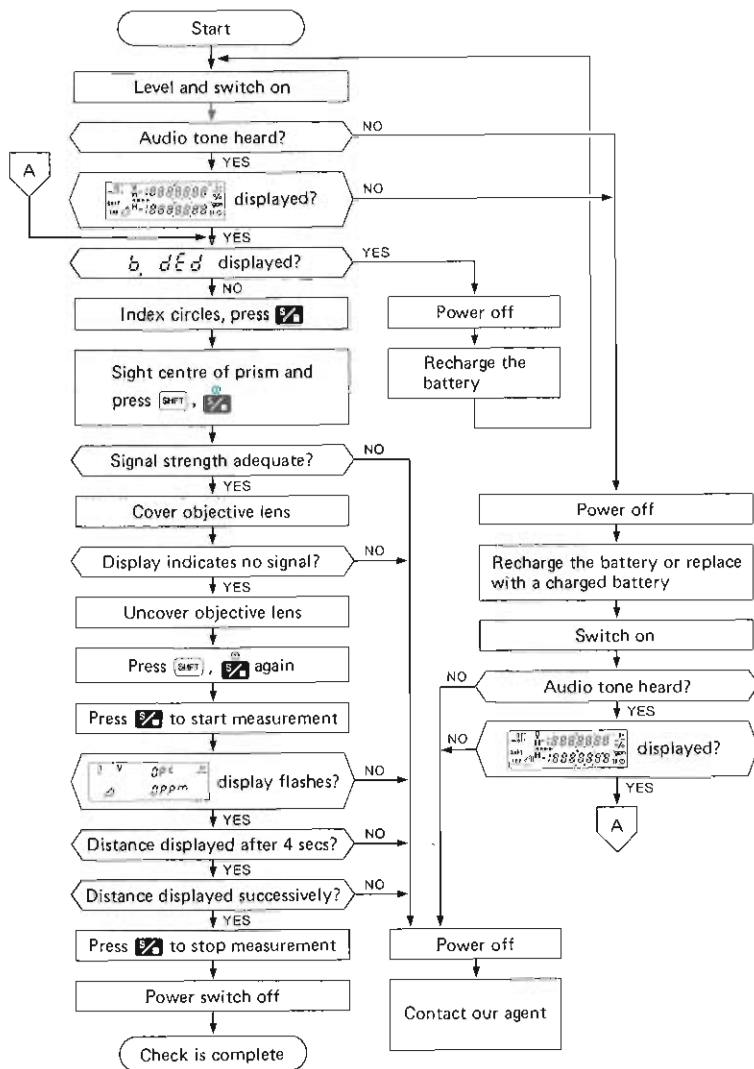

15. INSTRUMENT PARAMETERS

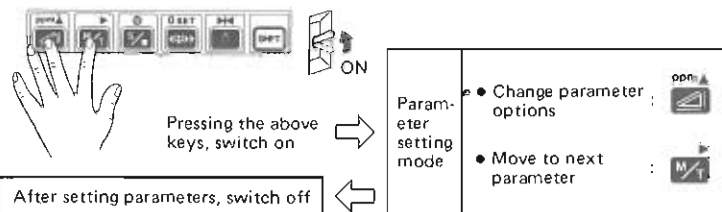

No.	Parameter		Options
1	Prism constant correction	F0	0mm
		*F3	-30mm
		F9	-90mm
			in 10mm steps
2	Distance measurement mode	*F0	Repeat measurements
		F1	Single measurement
3	Distance units	*F0	m (metres)
		F1	ft (feet)
4	Earth curvature and refraction correction	*F0	Not applied
		F1	Applied
5	Audio for return signal	*F0	On
		F1	Off
6	Vertical angle display format	*F0	Zenith 0
		F1	Horizontal 0 face left
		F2	Horizontal 0±90°/100gon/1600mil
		F3	% vertical angle
7	Vertical circle indexing	*F0	Rotate telescope
		F1	Observe face left, face right sightings
8	Auto vertical angle compensation	*F0	Applied
		F1	Not applied
9	Horizontal circle indexing	*F0	Rotate upper part
		F1	Auto 0SET at power on
10	Angle units	*F0	360°
		F1	400gon
		F2	6400mil
11	Auto power cut-off	*F0	Auto power cut-off after 30 minutes
		F1	Switch on/off with the SET5 switch
12	Auto illumination cut-off	*F0	Illumination on/off using [F6]
		F1	Illumination auto off after 30 seconds
13	Reticle illumination brightness	F0	High (Bright)
		*F1	Low (Dim)

* Parameter settings when the instrument left the factory.

- The parameter options selected are stored in the permanent memory even after power off.
- Parameter setting method:



- While pressing and , switch the power on.

No. 1 Prism constant correction

SHFT F3 -30

F3: -30mm

AP01S+AP01

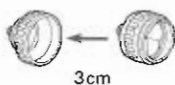

3cm

SHFT F4 -40

F4: -40mm

AP01



4cm

Possible to set a value between 0 and -90mm in 10mm steps.

SHFT F2 -20

F2: -20mm

Confirm option and move to next parameter.
(To exit, press , then switch off.)

No. 2 Distance mode

SHFT F0 FPP

F0: Repeat measurements:

- Initial measurement time is 4.3 seconds, then every 3.2 seconds in mm units.

SHFT F1 5.0g

F1: Single measurement:

- Measurement time 1.5 seconds in cm units.

To next page

Confirm option and move to next parameter.
(To exit, press , then switch off.)

No. 3 Distance units

SHFT F0 m

F0: Distance values displayed in metres

SHFT F1 ft

F1: Distance values displayed in feet

Confirm option and move to next parameter.
(To exit, press , then switch off.)

No. 4 Earth curvature and refraction correction

SHFT F0 OFF

F0: Not applied

P. 56

SHFT F1 ON

F1: Earth curvature and refraction correction applied

Confirm option and move to next parameter.
(To exit, press , then switch off.)

No. 5 Audio for return signal

SHFT F0 ON

F0: On (In return signal checking mode, audio tone sounds when signal is adequate for measurement.)

SHFT F1 OFF

F1: Off

To next page

Confirm option and move to next parameter.
(To exit, press , then switch off.)

No. 6 Vertical angle mode

V 6
SRFT F0

F0: Vertical angle (0 at Zenith)

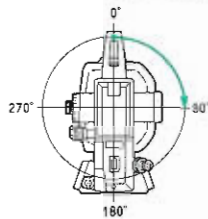

ppm
V 6
SRFT F1

F1: Vertical angle (0 Horizontal face left)

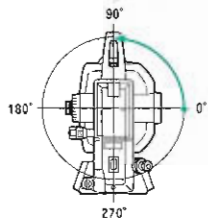

ppm
V 6
SRFT F2

F2: Vertical angle (0 Horizontal $\pm 90^\circ$ / 100gon/1600mil)

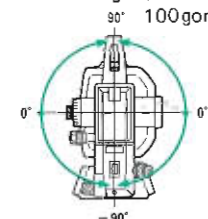

ppm
V 6
SRFT F3

F3: % vertical angle (up to 1000%)

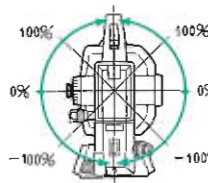

To next page

Confirm option and move to next parameter.
(To exit, press , then switch off.)

No. 7 Vertical circle indexing

V 7
SRFT F0 R

F0: Rotate telescope to index circle

ppm
V 7
SRFT F1 SET

F1: Observe face left, face right sightings

P, 54

Confirm option and move to next parameter.
(To exit, press , then switch off.)

No. 8 Vertical angle tilt compensation

V 8
SRFT F0 ON

F0: Applied

ppm
V 8
SRFT F1 OFF

F1: Not applied

Confirm option and move to next parameter.
(To exit, press , then switch off.)

No. 9 Horizontal circle indexing

H 9
SRFT F0 R

F0: Rotate upper part to index circle

ppm
H 9
SRFT F1 SET

F1: Auto zero set at power on.

To next page

Confirm option and move to next parameter.
(To exit, press , then switch off.)

No. 10 Angle units

V 10
SWFT H F0

F0: 360°



V 10
SWFT H F1

F1: 400gon



V 10
SWFT H F2

F2: 6400mil



Confirm option and move to next parameter.
(To exit, press , then switch off.)

No. 11 Auto power cut-off

SWFT 11 APC
F0 on

F0: Automatic power cut-off after 30 minutes of no key operation.



SWFT 11 APC
F1 OFF

F1: Power on/off using the power switch.

To next page

Confirm option and move to next parameter.
(To exit, press , then switch off.)

No. 12 Illumination auto cut-off

SWFT 12 LRC
F0 OFF

F0: Illumination on/off using the illumination key .



SWFT 12 LRC
F1 on

F1: Automatic illumination cut-off after 30 seconds.



Confirm option and move to next parameter.
(To exit, press , then switch off.)

No. 13 Reticle illumination brightness

SWFT 13 L
F1 L

F1: Low (Dim)



SWFT 13 L
F0 H

F0: High (Bright)



Confirm option and move to next parameter.
(To exit, press , then switch off.)

To Parameter No. 1 Prism constant correction

16. POWER SYSTEM

- The SET5 can be operated with the following combinations.

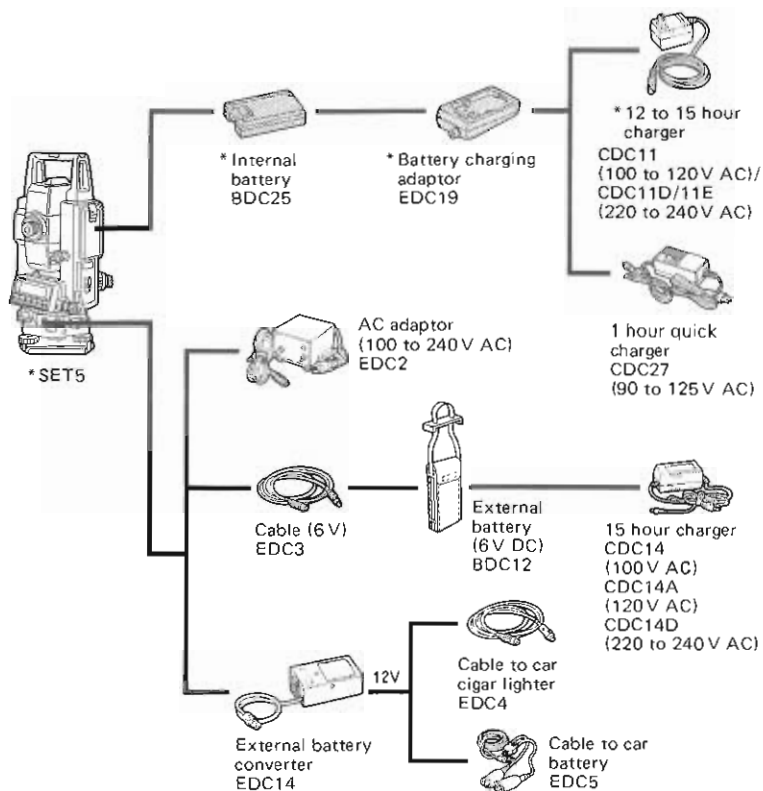

* Standard equipment. Items not marked with * are optional accessories.

Note: When using the external power supplies, it is recommended that the BDC25 battery be left in place to balance the weight on the axes.

Use the SET5 only with the combinations shown here.

- 1) Precautions for battery use and storage.
 - Charge the battery at least once a month if it is not used for a long time.
 - Store the battery in a place where the temperature is between 0°C and 40°C.
- 2) Precautions for battery charging using the standard charger.

To charge the battery, use only the recommended charger.

 - Charge the battery at a temperature between 10°C and 40°C.
 - Do not charge the battery for longer than the specified time.
 - When charging the battery, first mount it in the adaptor and connect to the battery charger, then connect the charger to the power supply. Check that the charging light is on. If not, switch the power supply off and on and check that the light comes on.
 - The battery charger normally becomes warm while charging.
 - Battery operating life is shortened at extreme temperatures.
- 3) Precautions for use of external power supplies.
 - When using a car battery, make sure that the polarity is correct.
 - Ensure that the car cigar lighter has 12V output and that the negative terminal is grounded.
 - Before using EDC2, set the voltage selector to the correct voltage.
 - EDC14 has a breaker switch. Normally the red mark appears on the breaker. If not, set the red mark in place.

17. REFLECTING PRISMS AND ACCESSORIES

- All Sokkisha reflecting prisms and accessories have standardized screws (5/8" x 11 thread) for easy compatibility.

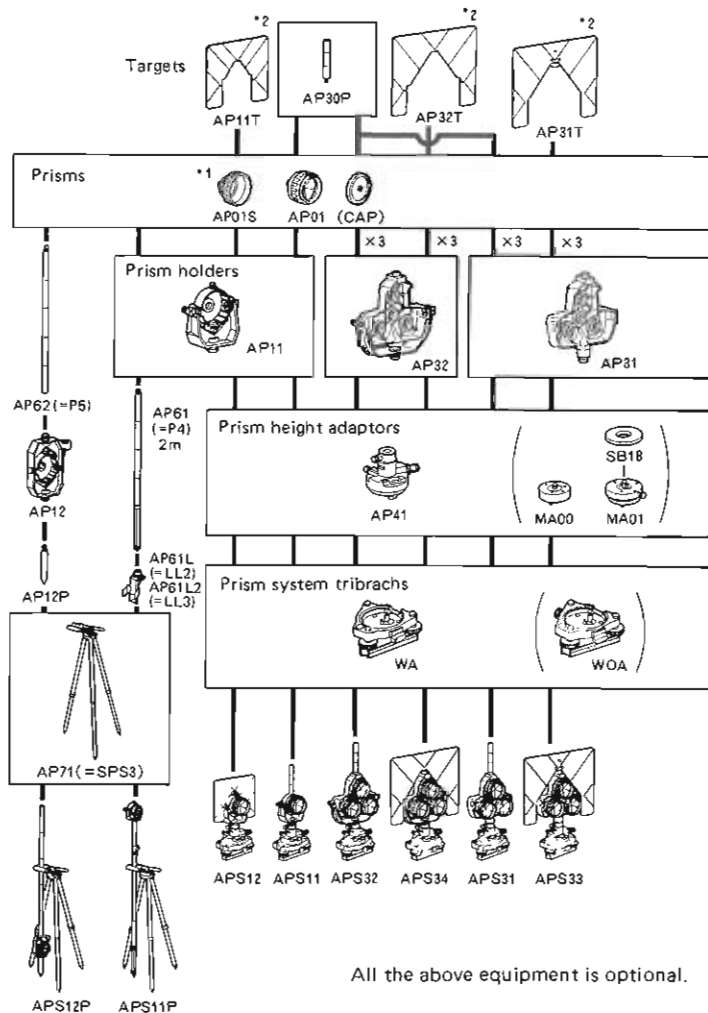

All the above equipment is optional.

*1: To change the stored prism constant value, see page 42.

*2: Fluorescent target paint finishing allows clearer sighting in adverse observing conditions.

- 1) Precautions for use of reflecting prisms.
 - Carefully face the reflecting prism towards the instrument; sight the prism target centre accurately.
 - To use the triple prism assembly AP31 or AP32 as a single prism (e.g. for short distances), mount the single prism AP01 in the centre hole of the prism holder.
- 2) Precautions for use of the instrument height adaptor AP41.
 - Check the optical plummet of the AP41 as described in Section 14.5. Check that the optical plummet of the AP41 sights the same point as that of the SET5.
 - Check that 236 (the height of the SET5 in mm) is displayed in the window of the instrument height adaptor AP41. The height of the AP41 can be adjusted as follows:

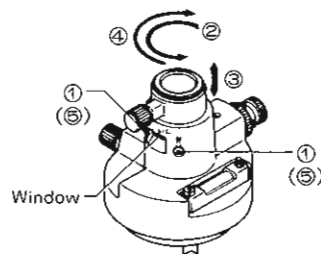

- ① Loosen the two fixing screws.
- ② Turn the centre part counter-clockwise to unlock it.
- ③ Move it up or down until "236" appears in the window.
- ④ Turn the centre part clockwise to lock it.
- ⑤ Tighten the fixing screws.

- 3) Precautions for use of tribrach.
 - Use the plate level on the AP41 to adjust the tribrach circular level as described in Section 14.2.

18. STANDARD EQUIPMENT



SET5 main unit	1	Plumb bob	1
Internal battery BDC25	1	Tool pouch	1
Battery charger		Screwdriver	1
CDC11/11D/11E	1	Lens brush	1
Battery charging adaptor		Adjusting pins	2
EDC19	1	Cleaning cloth	1
Tubular compass CP7	1	Atmospheric correction	
Lens cap	1	chart	1
Lens hood	1	Operator's manual	1
Vinyl cover	1	Carrying case SC80	1

19. MAINTENANCE

- 1) Wipe off moisture completely if the instrument gets wet during survey work.
- 2) Always clean the instrument before returning it to the case. The lens requires special care. Dust it off with the lens brush first, to remove minute particles. Then, after providing a little condensation by breathing on the lens, wipe it with a soft, clean cloth or lens tissue.
- 3) Store the SET5 in a dry room where the temperature remains fairly constant.
- 4) If the battery is discharged excessively, its life may be shortened. Store it in a charged state.
- 5) Check the tripod for loose fit and loose screws.
- 6) If any trouble is found on the rotatable portion, screws or optical parts (e.g. lens), contact our agent.
- 7) To maintain the accuracy of the SET5, check it for proper adjustment periodically.

APPENDIX 1: MANUALLY INDEXING THE VERTICAL CIRCLE

- Like all theodolites, the SET5 will have a vertical index error. The vertical index can be determined, and the index error removed, by the following procedure.

- 1) Set parameter 7 to "Indexing vertical circle by face left, face right readings".

P. 41

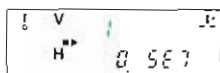

- 2) Carefully level the SET5 and switch the instrument on.

The prompt 1 is displayed.

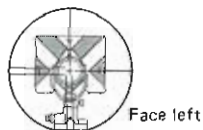

Face left



Press **SHIFT**, **O.SET**.

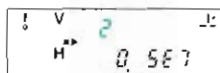

The prompt 2 is displayed.

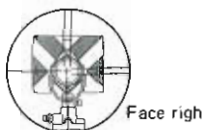

Face right



Press **SHIFT**, **O.SET** again.

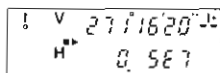

- 4) On face right, accurately sight the same target.
- When the vertical circle has been indexed, the vertical angle is displayed.

The horizontal circle should now be indexed.

Note: The vertical and horizontal circles must be re-indexed each time the SET5 is switched on.

APPENDIX 2: ACCURACY OF MEASUREMENT OF ATMOSPHERIC CONDITIONS

- 1) Atmospheric conditions

- The SET5 uses a beam of infra-red light to measure the distance. The velocity of this light in the atmosphere varies according to the temperature and pressure. For a variation in temperature of 1°C, the distance is changed by 1 ppm. For a variation in pressure of 3.8 mb, the distance is changed by 1 ppm. (A 1 ppm change is 1 mm for every 1 km of distance measured.) Consequently, temperature and atmospheric pressure must be carefully measured to correct the measured distances. (Temperature should be measured to the nearest 1°C and pressure to within 3.8 mb.)

- The ppm correction does not need to be applied when the calculated ppm value is within ±5 ppm and the distances are less than 200 m.

- 2) To obtain the average velocity along the measured light path, the average temperature and pressure is required.

- In flat terrain, measure the temperature at the midpoint of the line.
- In mountainous terrain, if the temperature and pressure at the midpoint can not be measured, take the temperature and pressure at the instrument and target and calculate the average values.

$$\text{Average temperature} = \frac{t_1 + t_2}{2}$$

$$\text{Average pressure} = \frac{p_1 + p_2}{2}$$

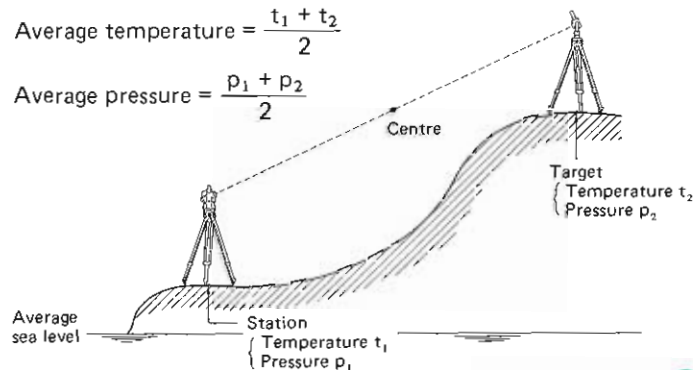

APPENDIX 3: EARTH CURVATURE AND REFRACTION CORRECTION

- The curvature and refraction correction can be selected using parameter No. 4. This correction is applied in the measurement of horizontal distance and height difference and uses an atmospheric refraction constant of 0.142.

(When the correction is not applied)

$$\text{Horizontal distance: } H = S \sin Z$$

$$\text{Height difference: } V = S \cos Z$$

(When the correction is applied)

$$\text{Horizontal distance: } H' = S \times \sin Z - \frac{1 - K}{R} \times S^2 \times \sin Z \times \cos Z$$

$$\text{Height difference: } V' = S \times \cos Z + \frac{1 - K}{2R} \times S^2 \times \sin^2 Z$$

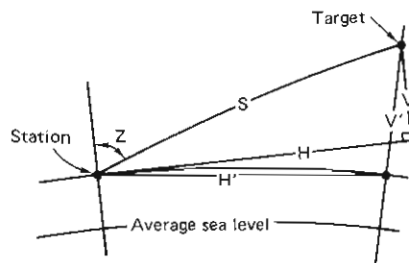

S: Slope distance after atmospheric correction

Z: Vertical angle (0 at zenith)

K: Atmospheric refraction constant (0.142)

R: Radius of the earth (6.372×10^6 m)

e.g. Amount of correction for a zenith angle of 70°

Distance S (m)	200	500	1000
H' - H (m)	-0.002	-0.012	-0.047
V' - V (m)	0.002	0.015	0.059

Note: The horizontal distance is a distance measured at the height of the surveying point above sea level. If required, reduce this distance to the average sea level and apply the local projection correction.

APPENDIX 4: STANDARD ACCESSORIES

1) Plumb bob

If the weather is calm, or for initial tripod centring, the plumb bob can be used for centring. To use, unwind the plumb bob cord and attach it to the hook inside the centring screw. Use the cord grip piece to adjust the cord length.

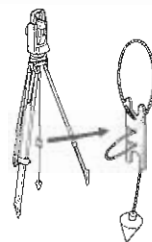

2) Tubular compass CP7 (accuracy $\pm 1^\circ$)

To mount the CP7, slide it into the tubular compass slot ①. To use, loosen the clamping screw to free the compass needle. Turn the instrument in the face left position until the compass needle bisects the index lines. The telescope is now aligned with magnetic north. After use, tighten the clamp.

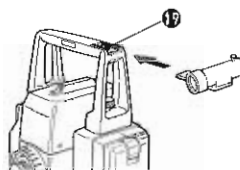

3) Tribrach

The SET5 instrument can be removed from the tribrach by rotating the tribrach clamp anticlockwise and carefully lifting the instrument up. (The SET5S has a shifting tribrach for quick centring, and the instrument can not be removed.)

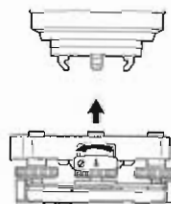

4) Handle

The carrying handle ① can be removed from the instrument by unscrewing the handle securing screw and sliding the handle to the side. When replacing the handle, ensure that the securing screw is fully tightened.

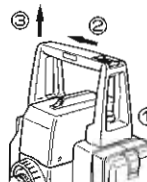

APPENDIX 5: OPTIONAL ACCESSORIES

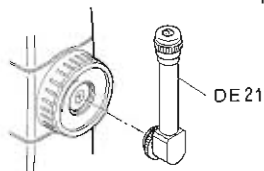

1) Diagonal eyepiece DE21

The diagonal eyepiece is convenient for near-vertical observations and in places where space around the instrument is limited. Remove the telescope eyepiece by unscrewing the mounting ring, and screw in the diagonal eyepiece.



OF1

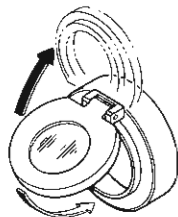

OF1A

2) Solar filter OF1/OF1A

For observations to the sun, and where glare is present. The OF1 and OF1A (flip-up type) filters are mounted on the objective lens.

3) Electronic field books SDR

The SDR series can collect and store all angle and distance values output from the SET5 data output connector (4). The stored data can be verified and printed in the field, then transmitted by cable or modem to an IBM-compatible office data processing system for final computation, printing and plotting.

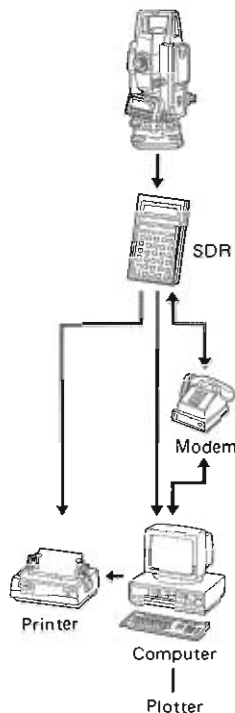

SDR features:

- Simple operation with clear menu and program display prompts.
- Wide choice of recording parameters.
- Recorded data can not be cleared from the memory until it has been transmitted or printed.
- Additional programs or data can be input to the SDR from an external computer.

SDR specifications:

- Power source: "AA" size batteries
Memory type: CMOS
Keyboard: 33 keys
Display: LCD
Baud rate: 300/600/1200/2400/
4800/9600 bps
- Operating temperature: 0 to 50°C (32 to 122°F)
Weight: 450g (1lb)

SPECIFICATIONS

Telescope

Length:	166 mm
Aperture:	45 mm
Magnification:	26x
Resolving power:	3.5"
Image:	Erect
Field of view:	1°30' (26m/1,000m)
Minimum focus:	1.3 m (4.3ft)
Reticle illumination:	Brightness selectable in 2 levels

Angle measurement

Type:	Incremental with zero index
Minimum display:	10" (0.002 gon/0.05 mil)
Angle range:	±1,999°59'50" ±1,999.998 gon ±19,999.95 mil ±999.909%
Automatic compensator:	Selectable on/off
Type:	Liquid
Range of compensation:	±3'
Measuring mode	
Horizontal angle:	Right/left/hold/repetition
Vertical angle:	0 at zenith 0 horizontal on face left 0 horizontal ±90°/100 gon/1,600 mil % vertical angle
Measuring time:	Less than 0.5 sec

Distance measurement

Maximum range: (When using Sokkisha reflecting prisms)	(Slight haze, visibility about 20 km, sunny periods, weak scintillation)
Average conditions:	Compact prism (CP series) 500 m (1,600 ft) 1-prism (AP series) 800 m (2,600 ft) 3-prisms (AP series) 1,000 m (3,300 ft)
Good conditions:	(No haze, visibility about 40 km, overcast, no scintillation) 1-prism (AP series) 900 m (2,900 ft) 3-prisms (AP series) 1,200 m (3,900 ft)
Standard deviation:	± (5 mm + 5 ppm × D)
Distance display range:	1,999.999 m/6,561.66 ft
Display of feet units:	Selectable
Minimum display:	Repeat 1 mm (0.01 ft) Single 10 mm (0.1 ft) Tracking 10 mm (0.1 ft)
Measuring modes:	Repeat/Single/Tracking
Measuring times:	

Distance mode	Measurement mode		
	Repeat	Single	Tracking
Slope distance	4.3s, then every 3.2s	1.5s	1.5s, then every 0.4s
Horizontal distance			
Height difference			

Atmospheric correction:	-499 to +499 ppm (in 1 ppm steps)
Prism constant correction:	0 to -90 mm (in 10 mm steps)
Earth curvature and refraction correction:	Selectable on/off
Audio target acquisition:	Selectable on/off
Signal source:	Infra red LED
Light intensity control:	Automatic

General

Display:	LCD 2-line, 8-digit display on both faces
Sensitivity of levels	
Plate level:	40"/2mm
Circular level:	10'/2 mm
Optical plummet	
Image:	Erect
Magnification:	3x
Minimum focus:	0.1 m (0.3ft)
Data output:	Asynchronous serial, RS-232C compatible
Self-diagnosis:	Provided
Power-saving cut-off:	30 minutes after last key operation (Selectable on/off)
Operating temperature:	-20°C to +50°C (-4°F to +122°F)
Power source:	Ni-Cd rechargeable battery BDC25 (6V)
Working duration:	17 hrs at 25°C/77°F (Angle measurement) 2.5 hrs at 25°C/77°F (Distance and angle measurement)
Charging time:	12 to 15 hrs (using standard charger CDC11/11D/11E)
Instrument height:	236mm
Size (without handle):	150 (W) × 165 (D) × 320 (H) mm (5.9 (W) × 6.5 (D) × 12.6 (H) inches)
Weight (with handle and battery):	6.4 kg (14.1 lbs)

ATMOSPHERIC CORRECTION CHART

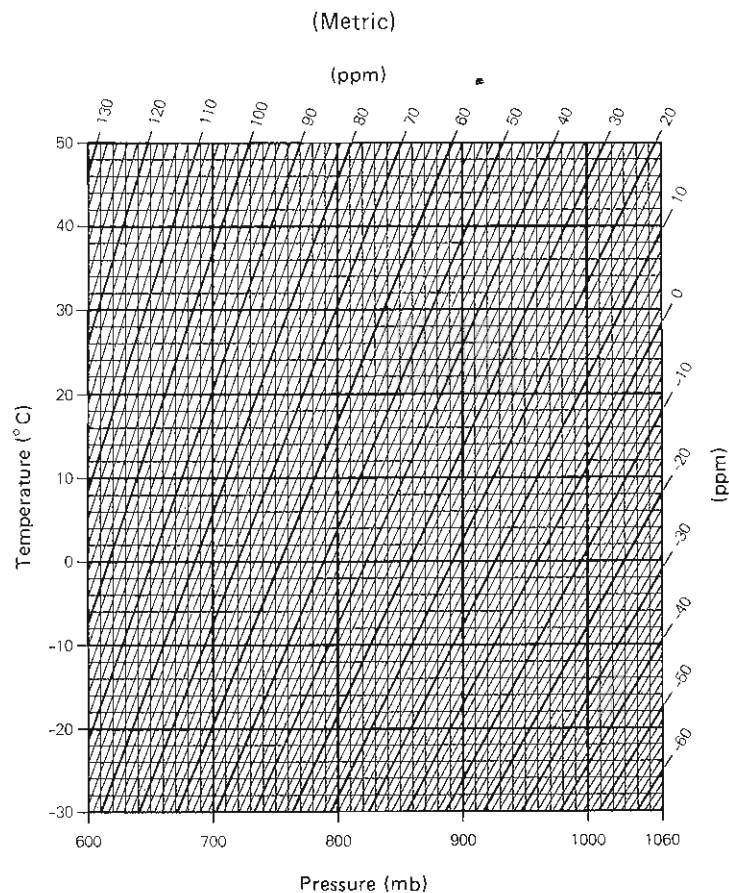

- This chart shows the correction every 2 ppm, while the atmospheric correction can be input to the SET5 for every ppm. To convert a pressure in mmHg to one in mb, divide by 0.75. e.g. 719 mmHg = (719 ÷ 0.75) = 959 mb

MEMO

THE LIETZ COMPANY

9111 Barton, P.O. Box 2934, Overland Park, Kansas 66201, U.S.A.
Phone 913-492-4900 Fax. 913-492-0188

SOKKISHA CANADA INC.

820 Denison Street, Unit 1, Markham, Ontario, Canada L3R 3K5
Phone 416-475-1450 Fax. 416-475-1453

SOKKISHA PTY. LTD.

107 Leicester Street, Carlton, Victoria 3053, Australia
Phone 03-347-5844 Fax. 03-347-0740

SOKKISHA NEW ZEALAND

20 Constellation Drive, Mairangi Bay, Auckland 10, C.P.O. Box 4464,
Auckland, New Zealand
Phone 09-479-3064 Fax. 09-479-3066

SOKKISHA EUROPE B.V.

Damsluisweg 1, 1332 EA Almere, P.O. Box 1292, 1300 BG Almere,
The Netherlands
Phone 03240-22880 Fax. 03240-26241

SOKKISHA U.K. LTD.

Unit 5, Oak Court, Betts Way, Crawley, West Sussex, RH10 2GB,
United Kingdom
Phone 0293-561618 Fax. 0293-561626

SOKKISHA DEUTSCHLAND GmbH

Emil-Hoffmann-Str. 7a, 5000 Koeln 50, Germany
Phone 2236-64058 Fax. 2236-62675

SOKKISHA FRANCE S.A.

12, Avenue Gabriel Peri, 78360 Montesson, France
Phone 1-30-53-09-73 Fax. 1-39-76-63-15

SOKKISHA ITALIA S.R.L.

Via Bologna 50, 10152 Torino, Italy
Phone 011-248-0080 Fax. 011-248-2702

SOKKISHA SWEDEN AB

Transportgatan 5, S-422 46 Hisings Backa, Sweden
Phone 031-581550 Fax. 031-528580

SOKKISHA BELGIUM N.V./S.A.

Sphera Businesspark, Doornveld 1-1A, B-1731 Zellik (Brussels),
Belgium
Phone 02-466-82-30 Fax. 02-466-83-00

SOKKISHA KOREA CO., LTD.

Rm. 401, Kwan Seo Bldg, 561-20 Sinsa-Dong, Kangnam-ku, Seoul,
Republic of Korea
Phone 02-514-0491 Fax. 02-514-0495

SOKKISHA SINGAPORE PTE LTD.

6001 Beach Road, #21-06, Golden Mile Tower, Singapore 0719
Phone 292-5483 Fax. 293-7916

SOKKISHA CO.,LTD.

1-1, TOMIGAYA 1-CHOME,
SHIBUYA-KU, TOKYO 151, JAPAN
PHONE 03-3465-5211 FAX.03-3465-5203
CABLE "SOKKISHA" TOKYO
TELEX SURSOK J28518